

Reyrolle
Protection
Devices

7SG1635 Ohmega 315

Protection Relays

Answers for energy

SIEMENS

SIEMENS
siemens-russia.com

Contents

- 1 Description Of Operation
- 2 Impedance Functions
- 3 Protection Schemes
- 4 Relay Settings
- 5 Performance Specification
- 6 Communication Interface
- 7 Application Guide
- 8 Installation
- 9 Commissioning
- 10 Maintenance
- 11 Diagrams
- 12 Autoreclose / Check Synchronising
 - Directional Earth Fault
 - Sensitive Earth Fault
 - Voltage Protection
 - Overcurrent Guard

The copyright and other intellectual property rights in this document, and in any model or article produced from it (and including any registered or unregistered design rights) are the property of Siemens Protection Devices Limited. No part of this document shall be reproduced or modified or stored in another form, in any data retrieval system, without the permission of Siemens Protection Devices Limited, nor shall any model or article be reproduced from this document unless Siemens Protection Devices Limited consent.

While the information and guidance given in this document is believed to be correct, no liability shall be accepted for any loss or damage caused by any error or omission, whether such error or omission is the result of negligence or any other cause. Any and all such liability is disclaimed.

7SG163 Ohmega 300 Series

7SG163 Protection Relay

Document Release History

This document is issue 2010/02. The list of revisions up to and including this issue is:
Pre release

2010/02	Document reformat due to rebrand

The copyright and other intellectual property rights in this document, and in any model or article produced from it (and including any registered or unregistered design rights) are the property of Siemens Protection Devices Limited. No part of this document shall be reproduced or modified or stored in another form, in any data retrieval system, without the permission of Siemens Protection Devices Limited, nor shall any model or article be reproduced from this document unless Siemens Protection Devices Limited consent.

While the information and guidance given in this document is believed to be correct, no liability shall be accepted for any loss or damage caused by any error or omission, whether such error or omission is the result of negligence or any other cause. Any and all such liability is disclaimed.

Contents

1	General	3
2	Protection Functions.....	3
3	Output Contacts	3
4	Status Inputs	3
5	Multiple Setting Groups	4
6	Instrumentation and Metering.....	4
7	Data Storage	5
8	Communications.....	5
9	Self Monitoring	6
10	Password Feature	6
11	User Interface.....	6
12	Settings and Displays.....	8
13	Relay Hardware.....	9

1 General

These relays are a range of numeric impedance measuring distance protection relays. The relays have independent measuring elements for each fault condition and zone of operation. This gives a true full scheme operation. The impedance measurement is a continuous process, therefore under impedance starting elements are not required. The relays can include a complete range of feeder protection features supplemented by control, metering, data storage and fibre optic data communication capabilities.

Supervisory components and self-monitoring features give a high confidence of full serviceability. A menu-based interface facilitates user friendly access to relay settings, meters and stored fault data.

The relay can be easily incorporated into substation control and automation systems.

2 Protection Functions

Table 1 illustrates the standard functions and Table 2 shows the standard schemes available in all relay variants;

Mho Characteristics	High Set Overcurrent
3 Zone	A.C. & DC SOTF
3 Pole Tripping	V.T. Supervision
Power Swing Blocking /Tripping	Loss of Load

Table 1 – Standard Protection Functions

Time Stepped Distance	Accelerated Underreach
Permissive Underreach	Permissive Overreach

Table 2 – Standard Schemes

In addition to these standard features, different model numbers are available which have extended functionality. These extended features are detailed in Section 12 of this manual.

3 Output Contacts

The basic relay model provides 5 output relays, three of which energise changeover contacts, the remaining two energise normally open contacts. The number of output contacts can be increased by groups of 8, to give a maximum of 29 output contacts.

Outputs are user programmable to operate from any or all of the protection functions. In addition they can be programmed to generate outputs for alarm conditions or operate on the energisation of a status input. The relay "Protection Healthy" output is energised whenever the relay is powered-up and working correctly. If the self-monitoring feature of the relay detects a hardware fault, or the relay power supply is lost, this contact will drop off.

In their normal mode of operation, output contacts remain energised for at least 100ms, or for the duration of fault. It is possible to increase this minimum operating time up to a maximum of 60seconds. Alternatively, outputs can be programmed to operate as latching contacts if required. Latched output relays can be reset either by pressing the TEST/RESET button, by sending an appropriate data communications command or electrically via a status input.

4 Status Inputs

3 plant status inputs are provided in the basic relay, this can be increased in groups of 8, using additional modules to give a maximum of 27 inputs. The inputs can be mapped to dedicated functions within the relay or can be mapped to functional logic blocks. The inputs can be configured to be high-speed signal channels or have a time delayed pickup or drop off function.

These relays include two counters, two timers, two inverters and two 4-input AND gates which can be used to produce simple custom logic as required by the user.

5 Multiple Setting Groups

These relays provide up to eight alternative settings groups, making it possible to edit one group while the relay protection algorithms operate using another 'active' group. The relay can be switched from one group of settings to another to suit alterations in the power system configuration. The process of changing the settings takes place sequentially, and may take up to 2s to update all the settings, during which time the relay remains operative.

A change of group can be achieved either locally at the relay fascia, remotely via a communications interface command or automatically by the energising of a status input. In the case of the last method, the 'Status Configuration'/'Settings Group Select' setting is used to configure any one (or more) of the status inputs to select a settings group. The selected group is then made active if the status input is energised and remains active for as long as the input remains energised. When the input is de-energised the relay returns to the original settings group.

All Settings are stored in non-volatile memory.

6 Instrumentation and Metering

6.1 Metering

The relay metering features provide continuous data accessed either from the relay fascia in "Instruments Display Mode" or via the data communications interface. While in the display mode pressing the \downarrow key accesses the following metering data:

6.2 Secondary Values

RMS values for the secondary I_A , I_B , I_C , I_E , V_A , V_B , V_C and V_R values measured by the relay.

6.3 Primary Values

RMS values for the primary I_A , I_B , I_C , I_E , V_A , V_B , V_C and V_R values on the system.

6.4 NPS Current

RMS value for the secondary I_2 measured by the relay.

6.5 Watts

Three phase exported primary power.

6.6 VARs

Three phase exported primary VARs.

6.7 Power Factor

Cosine of ϕ measured on phase A.

6.8 Load Direction

Forward, Reverse on each phase.

Indications showing the condition of the status input signals and the output contacts are available. Where the display indicates a **I** then that position is shown to be active.

The time and date is also displayed.

Where appropriate, additional meter displays are available depending upon the functions supplied with the relay. These will be described in the relevant sections.

7 Data Storage

Data records are available in three forms, namely fault records, waveform records and event records. All records are stamped with time and date. The relay incorporates a real time clock feature which keeps time even when the relay is de-energised.

Time and date can be set either via the relay fascia using appropriate commands in the System Configuration Menu, or via the communications interface. In the latter case, relays in a communications network can be synchronised by a global command. Alternatively, time can be synchronised via the IRIG B-12x interface in the relay.

7.1 Fault Records

When issuing a trip output under fault conditions, the relay illuminates the relevant LED(s) and, stores a fault record.

This fault record contains the date and time of the occurrence, the active setting group, the flags raised and the distance to fault (if fault location is enabled).

The fault record is viewed in the '**Fault Data Display Mode**' of the menu display system and can be viewed again at a later date. Records are stored for up to 10 faults, the older records being viewed by pressing the ↵ button. The displays are numbered from 1 to 10 with fault 1 indicating the most recent record. When each record is viewed the LED's which were indicating at the time of the fault are re-displayed.

The relay triggers the fault recorder (and waveform storage) when the internal logic detects a fault trip condition. Fault records are stored in capacitor backed memory.

7.2 Waveform Records

The waveform record feature stores analogue and digital information for all current inputs, voltage inputs, status inputs and output relays. Waveform storage is triggered by operation of any internal trip function.

In addition, the waveform records can be triggered remotely via a status input or via the serial communications interface. Waveforms are stored in a 1 second, rolling 'time window'. The memory is configured for 10 x 1s records. Records of different duration can be requested as a special function. The pre-trigger can be set in 10% steps over the record length.

Any new record over-writes the oldest when the data memory is full. All records are time and date stamped.

Waveform records are stored in RAM with a capacitor providing back-up during breaks in auxiliary supply.

The waveform records can only be examined once they have been downloaded into a suitable data analysis package such as Reydisp Evolution.

7.3 Event Records

The relay event recorder feature allows the time tagging of any change of state of the relay. Each event is logged with the full date and time and actual event condition every 2.5ms. The following events are logged:-

- Change of setting (though not the actual setting changes). Also indication of which group of settings is active.
- Change of state of Output Relays
- Change of state of Status Inputs
- Change of state of any protection characteristic
- Trip Indication Reset
- Trip Test
- Trip Supply Failure

Other events are available depending upon the features included in the relay -they are described with the relevant feature.

The event storage buffer holds at least 500 records. When the event buffer is full, then any new record over-writes the oldest.

Event records are stored in RAM with a capacitor providing back-up during breaks in auxiliary supply.

The event records can only be examined once they have been downloaded into a suitable data analysis package such as Reydisp Evolution or by interrogation of the SCADA system.

8 Communications

A front mounted RS232 port and two rear fibre optic communication ports are provided.

Communication is compatible with the IEC60870-5-103 transmission and application standards. The fibre optic interface gives superior EMC performance. A user friendly software package (Reydisp Evolution) is available to allow transfer of the following:

- Relay settings
- Waveform records
- Event records
- Instruments and meters
- Control Functions

This software can also be used to communicate with other Reyrolle Numeric Relays.

Communications operation is described in detail in the Reyrolle Informative Communication Interface Manual.

9 Self Monitoring

The relay incorporates a number of self-monitoring features. Each of these initiates a reset sequence, which can be used to generate an alarm output. In addition, the green Protection Healthy LED gives visual indication.

A watchdog feature monitors the microprocessor while the relay has a self-check feature for the program memory, which is continuously checked for data corruption.

The power supply is continuously supervised. Any failure is detected with sufficient time warning so that the microprocessor can be shut down in a safe and controlled manner.

10 Password Feature

The programmable password feature enables the user to enter a 4 character alpha-numeric code. The relay is supplied with the password function disabled. To enable the password feature the user must first enter a password. Verification of this is asked for and then this becomes the valid password.

As soon as the user attempts to change a setting the password is requested before any setting alterations are allowed. Once the password has been validated, the user is said to be "logged on" and any further changes can be made without re-entering the password. If no more changes are made within 1 hour then the user will automatically be "logged out", re-enabling the password feature.

Note that the password validation screen also displays a numerical code. If the password is lost or forgotten, this code can be communicated to Reyrolle Protection by authorised personnel, and the password can be retrieved.

The relay is supplied with the password set to "**NONE**" which means the feature is de-activated.

To de-activate the password, change the password to "**NONE**" the function will now be disabled.

11 User Interface

The user interface is designed to provide a user-friendly method of entering settings and retrieving data from the relay. The HMI is shown in Figure 1.

11.1 General Arrangement

All fascias include a liquid crystal display, 33 light emitting diodes, 5 push buttons and an RS232 data communications socket.

The LCD has a 20 character by 2-line display which is backlit. The backlight will remain illuminated for 5 minutes after the last keypress. This time is settable from 1-60 minutes.

11.2 Liquid Crystal Display

The liquid crystal display is used to present settings, instruments and fault data in a textual or graphical format.

The display back lighting is turned off to conserve power if no pushbuttons are pressed for a set time delay (Backlight Timer) within the range 1-60 minutes; the default setting is 5 minutes. After 1 hour, the whole display is de-activated, except in the case of when in the instruments mode, which will remain visible permanently.

The relay can be arranged to default back to the relay Identifier screen after a set time delay. This is set as the Default screens timer and can be set to Off, or to any value in the range 1–60minutes.

11.3 LED Indications

The following indications are provided:

Protection Healthy - Green LED.

This LED indicates that DC volts have been applied to the relay and that the relay is operating correctly. If a permanent fault is detected by the internal supervision, then this LED will continuously flash.

Red LED – latched or self reset.

These LED's indicate that a trip or protection operation as defined by customer setting has occurred. Such an operation may have been issued by any of the relays functions - all red LEDs are user programmable and can be assigned to any output function.

Listed below in Table 3 is an example of indications provided by the LEDs. Some of these will not be applicable when the relay is not provided with the relevant associated feature. Note a full list of the LED indications available in this model of the relay is provided in Section 4 of this manual.

Zone 1	Switch onto Fault
Zone 2	VT Fail
Zone 3	Overcurrent Highset
Zone 4	Overvoltage
Zone 5	Undervoltage
Phase "A"	IDMTL Overcurrent
Phase "B"	IDMTL Earth Fault
Phase "C"	Power Swing alarm
Earth	Power Swing trip
Carrier Receive 1	CB Fail Rretrip
Aided Trip	CB Fail Backtrip
DEF Forward	Broken Conductor
DEF Reverse	Stub Protection
Carrier Receive 2	Autoreclose in progress
DEF Aided Trip	Autoreclose lockout
Carrier Receive Guard	CB open

Table 3 – Typical LED Indications

11.4 Keypad

Five push buttons are used to control the functions of the relay by moving around the menu display. They are labelled \downarrow \uparrow \Rightarrow **ENTER** and **CANCEL**. Note that the \Rightarrow button is also labelled **TEST/RESET**.

Only two push buttons are accessible when the front cover is on. These are the \downarrow and \Rightarrow buttons, allowing read only access to all displays.

12 Settings and Displays

The basic settings/displays flow diagram is shown below. This diagram shows the three main modes of display, the SETTINGS DISPLAY MODE, the INSTRUMENT DISPLAY MODE and the FAULT DATA DISPLAY MODE.

On relay start up, the user is presented with a default relay identifier. This can be changed (In the SYSTEM CONFIG MENU) to some user-definable identifier or code if the user prefers.

Settings display mode is entered by scrolling down from the relay identifier display. The \Rightarrow key can then be used to move to the INSTRUMENT and FAULT DATA DISPLAY MODES in turn.

The settings display mode contains all the menus which hold the programmable settings of the relay. It contains a series of sub-menus a typical list with title displays are shown as follows:

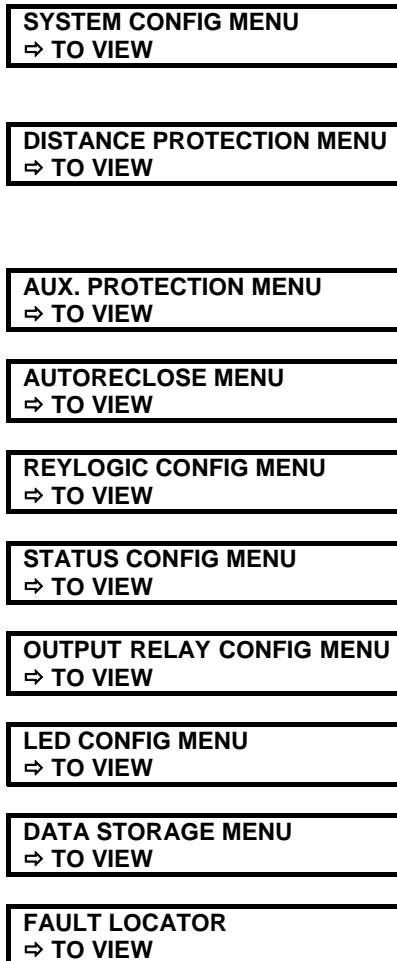

A sub-menu is opened by pressing the \Rightarrow key when viewing one of the above title screens. The settings within the sub-menu can then be viewed in turn. Leaving a sub-menu, by scrolling either upwards or downwards, causes it to be automatically closed. It must be re-opened in order to view its settings again.

- (1) Pressing \uparrow / \downarrow scrolls up / down, viewing the screens. All screens can be viewed even if the password is not known - the password only protects the relay against unauthorised changes.
 - (2) While viewing an editable screen, **ENTER** allows the user to change the displayed data, indicated by flashing character, as long as the changes are authorised via password verification. Pressing \uparrow / \downarrow increments / decrements that particular character, while \Rightarrow moves right along the edit field or fields. If \uparrow or \downarrow are held pressed while scrolling through a range of numerical settings then the rate of scrolling increases.
 - (3) **CANCEL** returns the screen to view mode and restores the most recently stored setting.
- If changes are made, pressing **ENTER** alters the values on that screen and **immediately** stores the changes into non-volatile memory. This also returns the screen to view mode and allows \uparrow / \downarrow to move to the previous / next screen.

There are eight separate 'Settings Groups'. The different settings groups can be viewed or edited independently and indication of which group is presently being viewed is given by the 'G?' character in the top left of the display.

The setting selections, setting ranges and default values can be found at the end of each relevant section in the technical manual.

13 Relay Hardware

The range of relays are housed in the Epsilon case – size 12 or 16.

The relay hardware is illustrated in Figure 1.

The build consists of up to eight internal hardware modules as well as the fascia module. All models are supplied with the following modules:

Module A	Power supply + basic I/O
Module E	Voltage inputs
Module F	Current inputs
Module G	Analogue input processing
Module H	Protection processor and controller

Modules B, C and D are optional, giving additional input/output capability.

The fascia PCB includes the human machine interface (HMI), with pushbuttons for entering settings, an LCD for displaying alphanumeric and optionally graphical information and LEDs for indication. A 21 pin RS232 D type connector is located on the front plate to allow local data communications.

Current and voltage input signals are carried from the input modules via the data acquisition bus (DAQ) to the analogue input processor card for processing. The processed inputs are in turn carried to the protection processor/controller module via the expanded I/O bus.

Two remote data communications interfaces - fibre optic - and an IRIG-B connector are located behind module H and connected into the controller card.

A 34 way ribbon cable connects the I/O and fascia modules to the processing and protection processor /controller modules.

13.1 Internal Construction

The design for the internal arrangement of each module has been chosen to provide a high level of EMI screening, using multi-layer PCBs with ground planes, RFI suppression components and earthed metal screens. The case is segregated internally into electrically noisy and quiet areas in order to improve noise immunity and reduce RFI emissions. The only direct connection from the quiet components to the external environment is via the serial communication interfaces. The optical interfaces are immune to radiated or conducted interference.

13.2 Front Cover

After the relay has been commissioned, a clear plastic front cover is fitted. This allows the user to see the entire front of the relay, but only allows access to the ↓ and ⇒ buttons, allowing all of the menus discussed previously to be viewed but not changed. The only 'action', which is permitted, is to reset the Fault Data Display, latched output relays and the trip LED by using the **TEST/RESET** function of the ⇒ button.

13.3 Terminal Blocks

These are of the standard Epsilon design, consisting of six blocks - behind modules A to F - with 28 terminals per block. All inputs and outputs (except for the serial communications interface) are made through these connectors. Where CT's and normally closed output contacts are fitted the terminals are provided with CT shorting contacts to provide system integrity when these modules are removed.

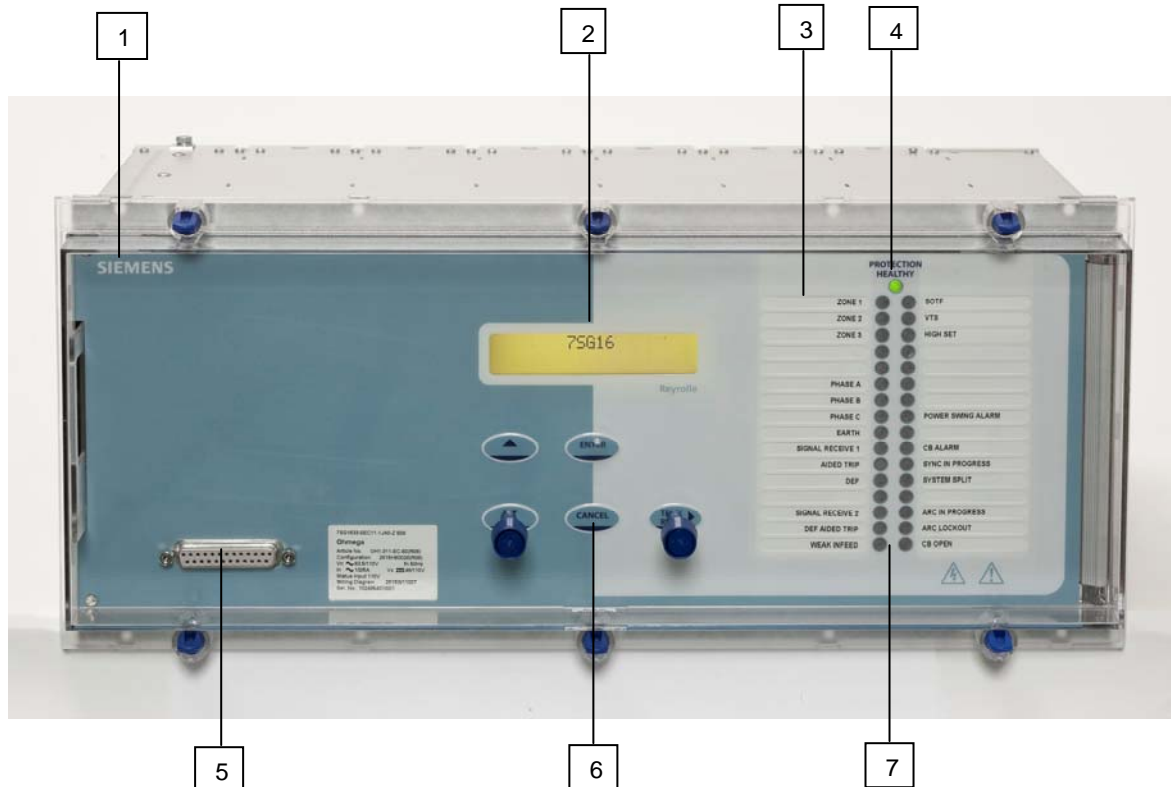

Figure 1–Human Machine Interface (HMI)

Features

- 1 Relay type
- 2 2 line 20 character back lit L.C. display
- 3 Alarm description
- 4 Protection healthy L.E.D.
- 5 Local RS232 port
- 6 Five button key pad
- 7 32 programmable alarm and trip L.E.D's

7SG163 Ohmega 300 Series

7SG163 Protection Relay

Document Release History

This document is issue 2010/02. The list of revisions up to and including this issue is:

Pre release

2010/02	Document reformat due to rebrand

The copyright and other intellectual property rights in this document, and in any model or article produced from it (and including any registered or unregistered design rights) are the property of Siemens Protection Devices Limited. No part of this document shall be reproduced or modified or stored in another form, in any data retrieval system, without the permission of Siemens Protection Devices Limited, nor shall any model or article be reproduced from this document unless Siemens Protection Devices Limited consent.

While the information and guidance given in this document is believed to be correct, no liability shall be accepted for any loss or damage caused by any error or omission, whether such error or omission is the result of negligence or any other cause. Any and all such liability is disclaimed.

Contents

1	Distance Protection Functions	3
1.1	Cross-Polarised Mho	3
1.2	Quadrilateral Characteristic	6
1.3	Impedance Zones	9
1.4	Power Swing Characteristics	9
1.5	Voltage Transformer Supervision (VTS)	12
1.6	Switch On To Fault (SOTF)	14
2	Auxiliary Functions	16
2.1	Fault Locator	16
2.2	Trip Circuit Supervision	16
2.3	High Set Overcurrent	16

1 Distance Protection Functions

1.1 Cross-Polarised Mho

It is fundamental to the requirements of discrimination that distance protection Zone 1 and 2 measuring characteristics for direct tripping are directional since they are required to detect faults in the forward direction only.

As with any measuring device, operation on, or very close to, the boundary of operation will be less decisive than that further inside the characteristic. It can be seen that the characteristic for Zones 1 and 2 pass through the origin, and thus, faults occurring very close to the relaying point will represent a boundary condition. In order to improve the operating speed, and to ensure correct directional response for such faults, a method known as cross-polarising is used.

A proportion (30%) of the voltage measured on a phase (or phases) not involved in the fault is added to the fault voltage used by the comparator (after being shifted 90° to bring it into phase with the fault voltage). The polarising voltage used will be different for each fault comparator, i.e. red-earth for a yellow-blue fault, red-blue for a yellow earth fault. For balanced (three-phase) faults the voltage in each phase will be equal, and so this will have no effect. For unbalanced faults, however, this "cross-polarising" changes the overall shape of the characteristic into a circle of diameter $Z_F - kZ_S$ as shown in figure 1, when the current is flowing in the forward direction. It can be seen from this diagram that the reach along the line angle is unaffected, but off angle, the characteristic expands. This expansion gives an increasing coverage of the resistive axis, and allows detection of higher resistance faults than the unpolarised mho characteristics. The healthy phase voltage, and thus the degree of expansion will depend largely on the source impedance, and thus the shape of the characteristic will depend upon the System Impedance Ratio (SIR). The higher the SIR, the greater the expansion.

When current flow is in the reverse direction, the shape of the characteristic will change again to give a small circle of operation in the forward direction (i.e. in the opposite direction from the fault). This ensures the stability of the relay for close-up reverse faults.

This expansion will only apply for unbalanced conditions. Some models of the relay employ a feature known as Voltage Memory. This provides a polarising vector derived from the pre-fault voltage which is applied for a limited time, after which the protection is inhibited. This provides a similar expansion for three-phase faults. Full details about voltage memory are provided under a separate heading, for models in which it is applied.

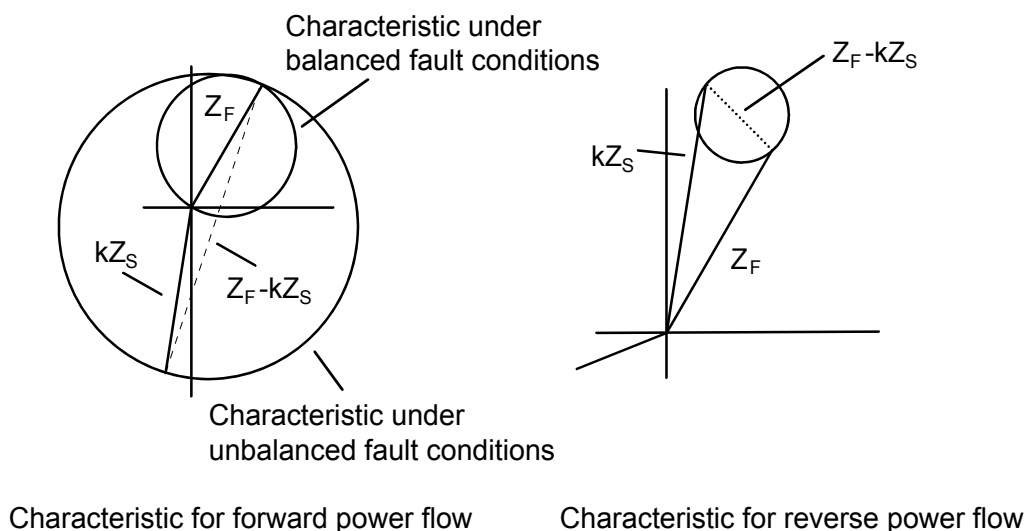
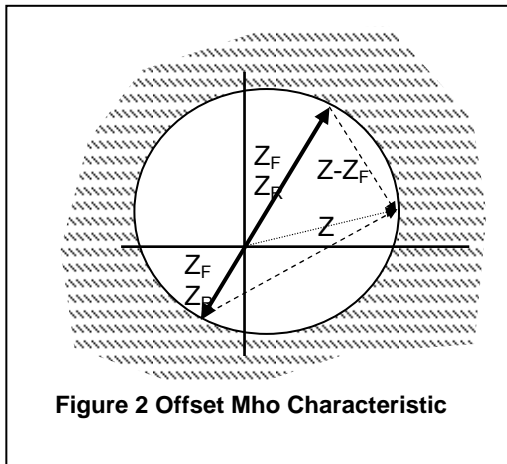

Figure 1, Cross-Polarised Mho Characteristic

1.1.1 Offset Mho Characteristic

The offset Mho characteristic is shown in figure 2. The characteristic is set with a forward reach, Z_F and a reverse reach, Z_R . This type of characteristic may be selected for Zone 3, and it provides time delayed back-up for faults behind the relaying point.



In addition to this, the origin is not a boundary condition as it is for zones 1 and 2, so the offset zone can be used in schemes to provide positive operation for marginal conditions (see Switch-onto-fault logic).

1.1.2 Fault Configuration

A distance relay must measure the impedance correctly for all types of power system faults (single-phase, two-phase and three phase). For each fault type the effective impedance at the relaying point will be different because the path that the current takes will be different in each case, as illustrated in figure 3 below ;

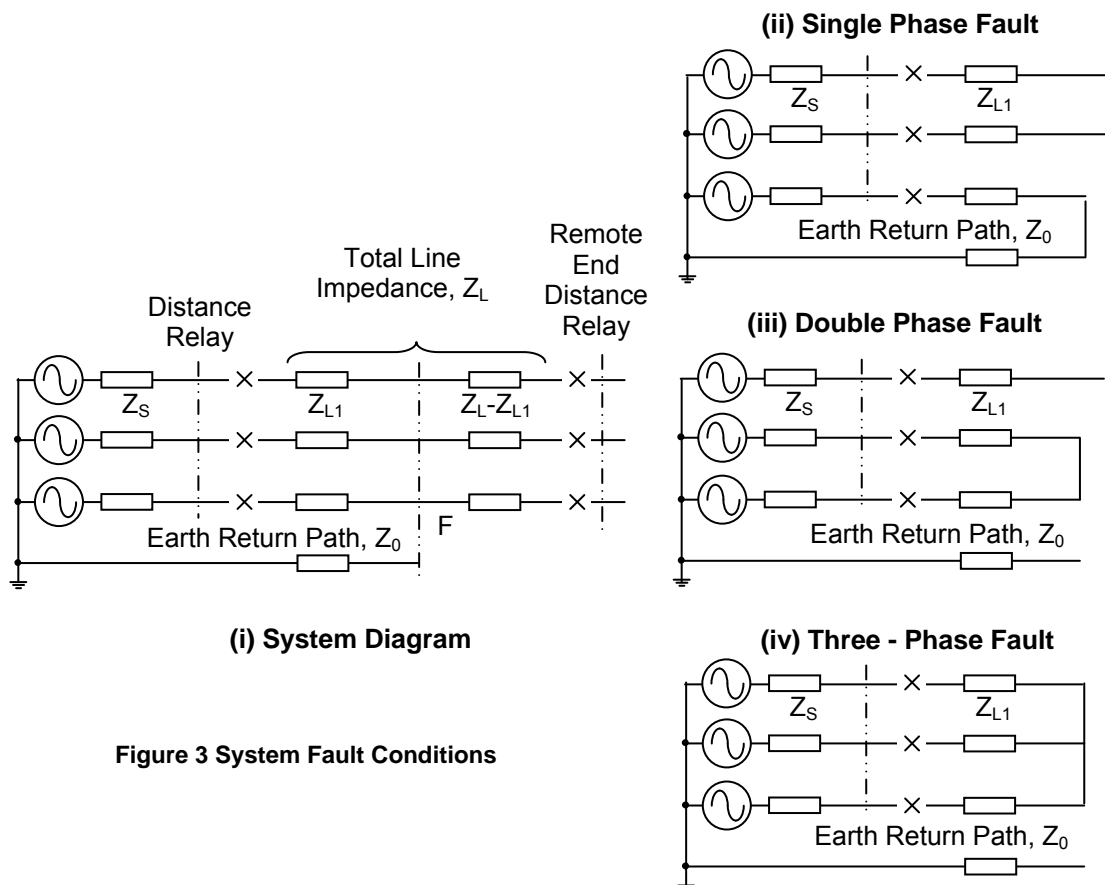
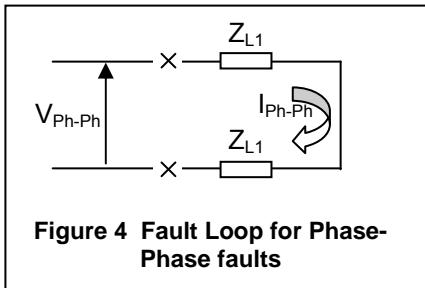

Figure 3 System Fault Conditions

To correctly measure the impedance to the fault point, the correct current and voltage must be applied to the relay. The relay impedance setting is made in terms of the positive sequence impedance to the point of reach which means that the relay setting is the same for all types of fault.

The relay uses discrete measuring elements for each fault type in each zone. The quantities measured by each of these elements are described in the following sections.

1.1.3 Phase Faults



There are three phase fault elements in each zone looking at red-yellow, yellow-blue, and blue-red phase faults respectively. These elements measure the phase-phase voltage, and phase-phase current for their particular phases. As can be seen from figure 4, this leads to a loop impedance of $2Z_L$.

1.1.4 Earth Faults

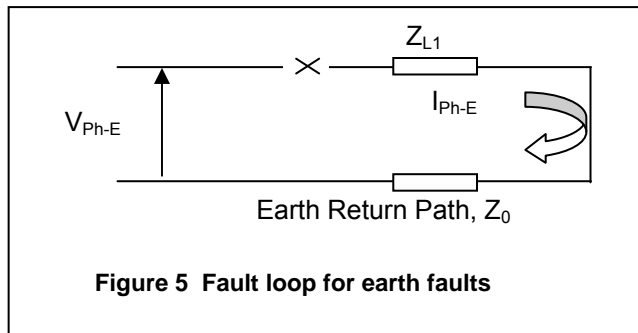

When considering earth faults, the relay is actually presented with a loop impedance of $Z_L + Z_N$, where Z_L is the impedance in the line to the fault and Z_N is the earth return path, as shown in figure 5. This can also be compensated for by using a combination of the current flowing in the line and neutral circuit but the problem is that the complex impedance Z_N is not known and is not readily available by measurement.

Conventionally the known parameter available for the line is the zero sequence impedance. (If it is not known, it can be measured for any particular line). The zero sequence impedance, like the positive sequence impedance is proportional to the line length

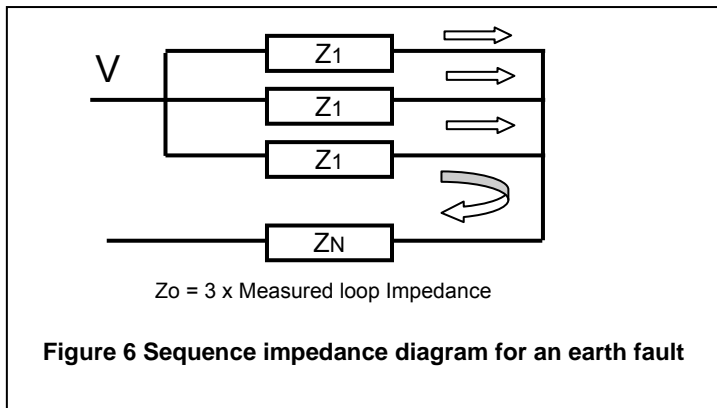

Figure 6 shows the method utilised to measure the zero sequence impedance of a line that gives the expression;

$$Z_0 = 3 \left(\frac{Z_1}{3} + Z_N \right)$$

or
$$Z_N = \frac{(Z_0 - Z_1)}{3}$$

and the ratio
$$\frac{Z_N}{Z_1} = \frac{1}{3} \left(\frac{Z_0}{Z_1} - 1 \right)$$

$$Z_N = \frac{1}{3} \left(\frac{Z_0}{Z_1} - 1 \right) Z_1$$

hence

$$Z_N = K_0 Z_1$$

where

$$K_0 = \frac{1}{3} \left(\frac{Z_0}{Z_1} - 1 \right)$$

This is a convenient factor to use in the phase comparison logic as the actual value of Z_0 is not required provided the ratio Z_0 / Z_1 and the phase angles of Z_0 and Z_1 are available. The K_0 factor described above must of course take into account the phase angles of Z_1 and Z_0 in the calculation for K_0 .

The advantage of using the method described above is that the ratio Z_0/Z_1 is a relatively simple calculation and can be obtained using any convenient dimensions (eg Primary Ohms, Secondary Ohms, Ohms/Km etc) provided the zero phase sequence value and the positive phase sequence value are expressed in the same units.

When the reach setting Z_1 , the ratio Z_0 / Z_1 , the line angle, and the angle of Z_0 are entered the relay calculates the composite value.

$$K_0 = \frac{1}{3} \left(\frac{Z_0}{Z_1} - 1 \right)$$

and this value is taken into account for a polarised mho characteristic using the complex expression.

$$IZ + K_0 I_N Z_1 - V \text{ within } 90^\circ \text{ of } V + V_p \quad \text{where } I = \text{Phase current}$$

Z_1 = Positive phase sequence impedance of zone setting

$$K_0 = 1/3 (Z_0/Z_1 - 1)$$

I_N = Earth fault current

V = Phase-earth fault voltage

V_p = Polarising voltage

1.2 Quadrilateral Characteristic

In addition to MHO characteristics, some models of the relay have the option of quadrilateral characteristics for earth fault coverage. The quadrilateral characteristic can be set according to resistive coverage, reactive coverage and the line angle. The resistive cut off blinder is set to the same angle as the line angle.

1.2.1 Cross-Polarised Quadrilateral

A typical polarised quadrilateral characteristic, as would be used for Zones 1 and 2, and the reverse looking Zone 4 is shown below. This characteristic is constructed using two directional characteristics (hence the need for polarising), a reactance characteristic and a resistance characteristic.

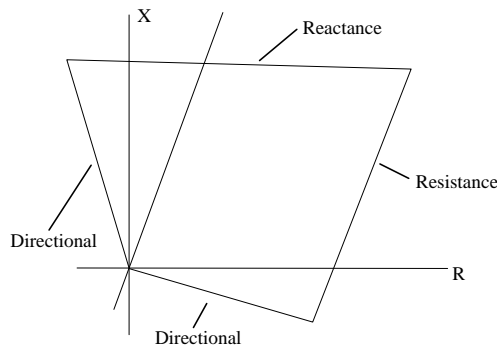

Figure 8 Forward-looking Quadrilateral Characteristic.

Because of the polarising quantities, the directional lines will exhibit a shift toward the source during unbalanced faults, ensuring operation for close up forward faults, and stability for close up reverse faults.

A self-polarised directional characteristic is given by the vector equation

$$IZ_F \equiv V$$

Dividing through by I gives

$$Z_F \equiv Z$$

In other words, we compare the angle of the fault impedance with the angle of the forward replica impedance, as shown below. If the two angles are within 90° , then the comparator operates, as shown in the diagram below;

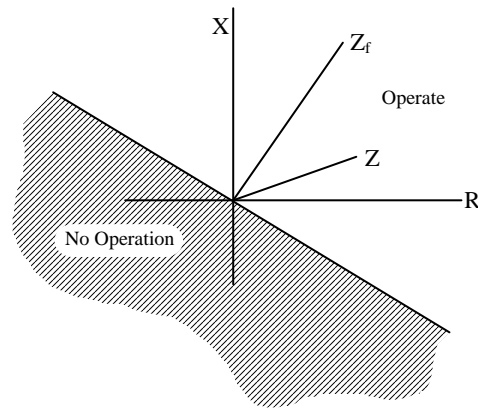

Figure 9 Operating Zone of the directional element.

In order to obtain more reliable operation for close up fault conditions, the directional characteristic is polarised from a source other than the fault voltage, which will allow accurate determination of the fault direction for close-up faults. The vector equation for the polarised characteristic is;

$$IZ_F \equiv V_P$$

The magnitude and angle of V_P will depend on a combination of factors, but for unbalanced fault conditions it will be related to the source impedance Z_S . For convenience the vector equation is

$$Z_F \equiv Z_S$$

The characteristic is shown below;

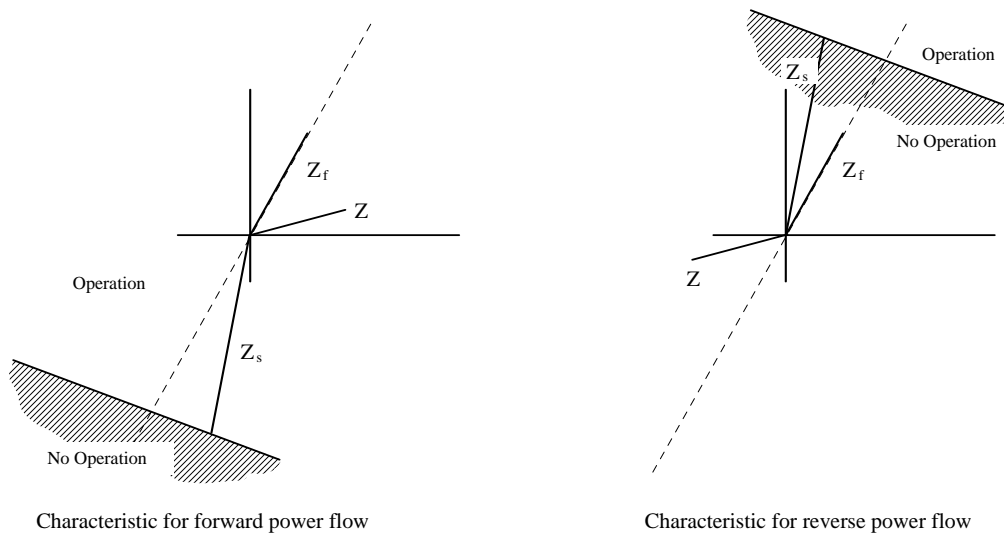

Figure 10 Polarised Directional Characteristic

As can be seen, the characteristic moves behind the origin for forward faults, and forward of it for reverse faults. In addition, as the SIR level increases (Z_S increases relative to Z) the characteristic moves further from the origin. This ensures operation for close-up forward faults and stability for reverse faults.

The Reactance Characteristic is shown in Figure 11, and consists of a straight line which cuts the reactive axis at a value X_F . This requires a replica impedance Z_F of magnitude $X_F \sin \Phi_X$ and angle Φ_X . If the reactive component of the fault impedance is less than this value, the comparator operates. The angle Φ_X is normally set at about -3° to the horizontal, so that the characteristic slopes in order to ensure that with increasing resistance, the relay will not overreach beyond setting. This angle is referred to as the reactive drop angle.

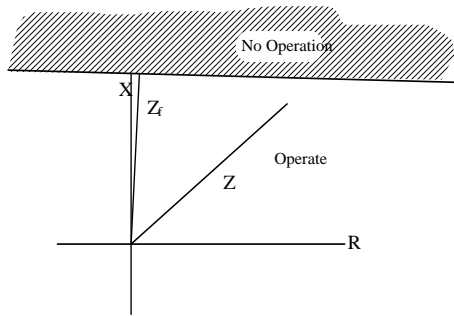

Figure 11 Reactance Characteristic

The vector equation for the reactance characteristic is

$$IZ_F - V \equiv IZ$$

which becomes

$$Z_F - Z \equiv Z_F$$

If the angle between Z_F and $Z_F - Z$ is less than 90° , the comparator will operate.

The Resistive Characteristic is shown below, and is identical in nature to the reactance characteristic, except for the choice of replica impedance. This gives a characteristic which is inclined at the line angle, but crosses the resistive axis at a value R_F , giving increased resistive coverage over the entire line length. The vector equation is again

$$IZ_F - V \equiv IZ$$

which becomes

$$Z_F - Z \equiv Z_F$$

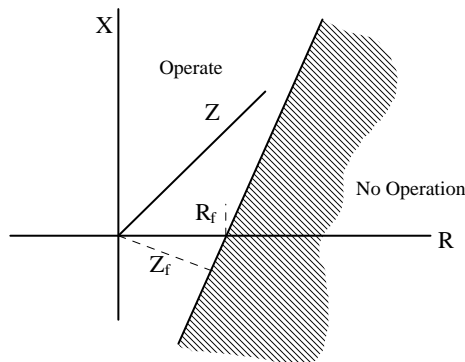

Figure 12 Resistance Characteristic

The replica impedance Z_F has magnitude $R_F \cos(\Phi_L - 90^\circ)$ and angle $\Phi_L - 90^\circ$.

1.2.2 Offset Quadrilateral Characteristic

A typical offset quadrilateral characteristic is shown below. This is constructed using forward and reverse resistance characteristics, and forward and reverse reactance characteristics. This would be used for the offset zone 3 characteristic.

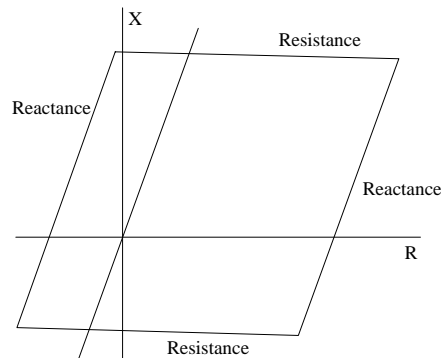

Figure 13 Typical offset quadrilateral distance characteristic

1.3 Impedance Zones

The relay has three zones of protection as standard; zone 1 & 2 are polarised to operate in the forward direction while zone 3 can be set as either forward, reverse or as an offset zone. If the zone 3 is set as an offset zone then the minimum reverse reach is the same as the minimum forward reach. A fourth zone is available as an option in some models. This is a reverse-looking polarised characteristic. It is commonly used as a non-tripping zone in conjunction with a blocking scheme.

The accuracy of the relay is $\pm 5\%$ or 0.1Ω , whichever is larger. The range for each of the impedance elements is from 0.1Ω to 250Ω , regardless of the output of the current transformers. Obviously, the settings used for 5A CTs will be smaller than those used for 1A CTs, on an equivalent circuit.

With 5A CTs the minimum advisable setting is 0.1Ω .
 With 2A CTs the minimum advisable setting is 0.2Ω .
 With 1A CTs the minimum advisable setting is 0.5Ω .

For 2A and 1A, the settings can be reduced below these minimums, but the relay accuracy will be reduced.

1.4 Power Swing Characteristics

1.4.1 Applications

A power swing is the result of a change in angle between two power systems. Each system can be subjected to disturbances such as faults, loss of load, loss of large generation, etc. which in turn, may result in excursions of generator rotor angles. Assuming a two-machine model, one generator working at local end of the line will rotate with different angular velocity with reference to the remote generator until reaching a new stability point.

This phenomenon can result in oscillating power between two ends of the protected line. At the relaying point, a distance element measures these as impedance oscillations which may encroach a set protection impedance characteristics and trip a line. In order to prevent from mal-tripping, a power swing blocking function may be implemented.

There are various methods detecting power swings encroaching impedance measuring elements. The most common practice is to plot an impedance curve which encloses tripping impedance characteristics. The relay employs two independent shapes of characteristics for this purpose i.e. polygonal and circular.

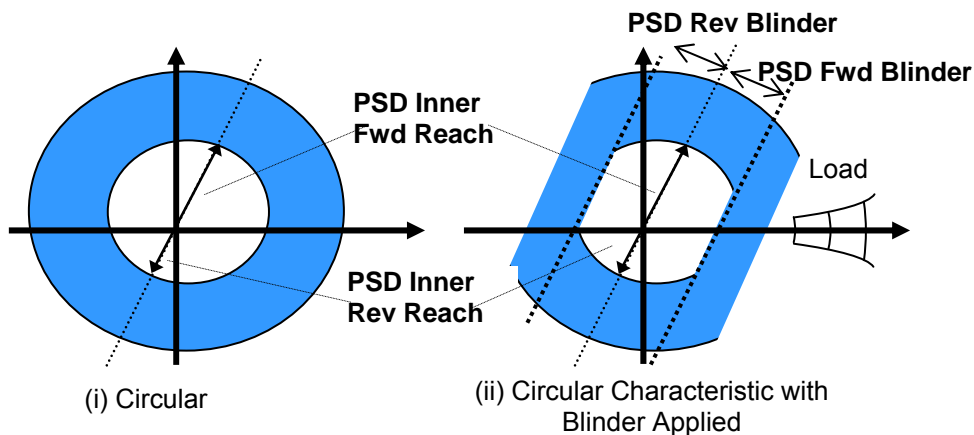
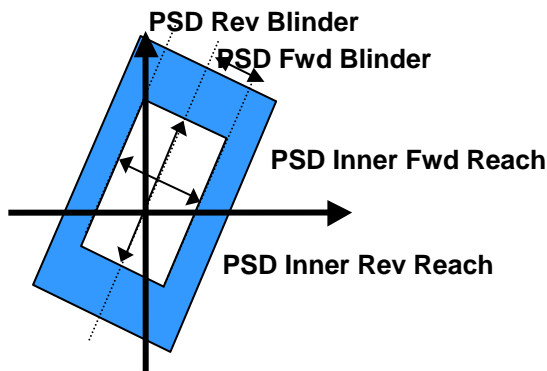

Figure 14 Circular Power Swing Detection Zones

It is possible to apply forward and reverse resistance blinders to the circular characteristic, to separate it from the load impedance if necessary. The user can enable or disable these blinders to achieve the best-tailored shape with reference to load and tripping zones.



The rectangular power swing detection characteristic (see Figure 15) is designed for use with quadrilateral characteristics – this is simply set in terms of forward and reverse reach (giving the reactive reach) and forward and reverse blinders (giving the resistive reach)

Figure 15
Rectangular Power Swing Detection Zones

1.4.2 Power Swing Detection.

The relay uses 2 zones of protection to detect a power swing condition, defined as the inner and the outer zones. Each of these zones consists of a phase to phase fault comparator applied to the Yellow-Blue phase. Upon operation of the outer zone, a timer is started. If the time between the operation of the outer zone and the inner zone is greater than the relay PSD Transit time, the relay will raise the power swing alarm.

The reach of the power swing detection zones are set in terms of impedance for the inner reach. The outer reach is then set by a multiplying factor, usually 1.5 times the inner reach.

$$Z_{PSB(Outer)} = k \cdot Z_{PSB(Inner)}$$

The inner reach should be either equal to or just above the furthest reach setting of the relay, so that all zones of the relay are contained completely within the inner power swing detection zone. A check should also be made on the outer reach with reference to the maximum feeder load. The outer reach should not encroach upon the load condition under any circumstances. This check is best carried out by inspection – if necessary sketching out the characteristics to ensure correct co-ordination. The blinders can be applied to prevent load encroachment if this is a possible problem.

1.4.2.1 Power Swing Blocking.

Once a power swing has been detected it is often desirable to prevent operation of the relay during a power swing condition. The relay can be set to block operation of any combination of protection zones within the relay.

Faults can occur during power oscillations, so it is necessary to provide a mean of distinguishing between a power swing and a genuine fault condition. Because a power swing condition is always a balanced three-phase condition, the relay can use the level of negative phase sequence current on the system to determine between these two conditions.

Under balanced conditions, an untransposed transmission system can produce negative phase sequence currents of up to 14% of positive phase sequence current. Under fault conditions, however, the level of negative sequence current will be much higher. Thus, when the negative sequence current exceeds 25% of the positive sequence current, the power swing blocking will be removed, allowing the relay to operate.

1.4.3 Settings.

<i>Power Swing detector</i>	ENABLE/ DISABLE
<i>PSD Zone Blocking</i>	— — — —
<i>PSD Shape</i>	CIRCULAR, RECTANGULAR
<i>PSD Blinders</i>	ENABLE / DISABLE
<i>Inner Forward Impedance</i>	0.1-250 ohm in 0.1 ohm step
<i>Inner Reverse Impedance</i>	0.1-250 ohm in 0.1 ohm step
<i>Inner Blinder Forward</i>	0.1-250 ohm in 0.1 ohm step
<i>Inner Blinder Reverse</i>	0.1-250 ohm in 0.1 ohm step
<i>Multiple (Outer Impedance)</i>	1.05-250% in 0.01% step
<i>PS Timer</i>	0-1000ms in 5ms step

Status Inputs: N/A

Relay Outputs: **POWER SWING ALARM**

1.5 Voltage Transformer Supervision (VTS)

1.5.1 Applications.

A protection voltage transformer (V.T.) would normally be connected to the protection relay terminals via a fuse or a miniature circuit breaker. Operation of these would remove the voltage source for one or more phases. With load current flowing in the circuit the measured impedance (V/I) would be zero, thus it would appear to the relay that a fault had occurred, possibly causing a healthy system to be tripped out. The V.T.S. is used to identify this condition and in some cases prevent tripping by blocking the operation of one or more of the zones of protection.

1.5.2 Description of Operation.

1.5.2.1 Residual Current and Voltage

The following description applies if the VTS Input Source is set to Residual V and I.

In the event that one or two phases of the VT are lost, a residual voltage will be developed across the relay terminals, without a corresponding residual current being present. The relay incorporates a zero sequence overvoltage detector and a zero sequence undercurrent detector. The simultaneous operation of both of these detectors indicates a fuse failure. This generates a signal that gives an alarm and may be used to inhibit the distance protection (the relay may be set to ALARM or ALARM & INHIBIT).

If, during this voltage transformer failure, an earth fault occurs, the zero sequence current will increase which will then remove the VTS blocking and allow the relay to trip (the indication may be incorrect due to the relay not having all the voltage inputs).

If the VTS condition remains on the system for a time longer than the "VTS Latch PU Delay" time setting found in the Reylogic Configuration (5 seconds default), then the VTS condition will latch in. When latched the VTS blocking will not be removed by the presence of zero sequence current and will only be removed when the voltages are restored..

If a phase fault occurs during the voltage transformer failure there will be no zero sequence current. Thus, if a phase fault occurs during a VT failure, the zero sequence undercurrent detector will not reset itself and the relay will remain blocked.

For this reason there are two settings for the VTS mode:

VTS MODE: ALARM ONLY / ALARM AND INHIBIT

VTS PHASE FAULT INHIBIT: ENABLED / DISABLED

With the relay in ALARM ONLY mode, the relay will raise an alarm, when it detects a VT failure, but will not prevent the relay from tripping.

With the VTS mode set to ALARM AND INHIBIT the relay will inhibit the *earth fault elements* from causing a trip.

If VTS PHASE FAULT INHIBIT is ENABLED, the relay will remain stable during a two phase VT failure, but will not operate if a phase fault occurs while the VTS is picked-up.

If VTS PHASE FAULT INHIBIT is DISABLED, the relay will trip if the phase fault elements pick-up, regardless of whether the relay is set to ALARM AND INHIBIT or ALARM ONLY. This means that if two phases of the VT fail, the relay will trip, regardless of whether the relay is set to ALARM & INHIBIT or ALARM ONLY.

1.5.2.2 NPS Current and Voltage

Alternatively, negative phase sequence current and voltage can be used to detect the loss of a VT fuse. The operation is similar to that of the residual operation described above except that NPS current and voltage mismatch is used to detect the operation of a fuse. The main advantage of the NPS system is that during a phase to phase fault, NPS current is generated which will cause the VTS trip inhibit to be removed such that once again the relay can trip correctly for the fault. For this reason, if NPS is selected, the Phase Fault Inhibit should always be set to Enabled.

The NPS settings are scaled such that they are equivalent to the Residual settings i.e. the voltage setting $V_{op} = 3V_0$ for Residual or $3V_2$ for NPS.

1.5.3 General Operation

This arrangement is relatively simple and readily lends itself to application assessment in terms of its effect, if any, on the earth fault protection coverage. The minimum time response is arranged to be approximately 2/3 of the minimum operating time of the zone 1 to ensure an adequate time margin for blocking.

The inhibit signal is available immediately whereas the alarm signal has a time delay, which can be set from 0-60000ms to prevent nuisance alarms occurring during circuit breaker switching.

The above principle is recommended in applications for the transmission and sub-transmission system where the maximum residual current is 5% or less of the load current.

VTS ALARM contacts can be selected from the OUTPUT MENU.

Where an MCB is used rather than Fuses, the loss of all three-phases of the VT can be detected by connecting a contact from the MCB to the VT CCTS ISOLATED Status Input of the relay. This will energise the Status Input when the VT MCB trips.

1.5.4 Settings.

<i>VT Supervision</i>	Disable, Enable
<i>VTS Mode</i>	Alarm Only / Alarm & Inhibit
<i>VTS Latched Operation</i>	Disable, Enable
<i>VTS Phase Fault Inhibit</i>	Disable, Enable
<i>VTS Input Source</i>	Res V&I/NPS V&I
<i>VTS Ires Level</i>	0.05..2 (0.3 X In)
<i>VTS Vop Level</i>	1..100 (20)
<i>VTS Latch PU delay</i>	0..60000 (5000)
<i>VTS Alarm PU delay</i>	0..60000 (100)

Status Inputs: **VT CCTS ISOLATED**

Relay Outputs: **VTS ALARM**

1.6 Switch On To Fault (SOTF)

1.6.1 Applications

The Zone 1 instantaneous elements of the distance protection are directional and rely upon polarisation from either the faulted phase and/or a healthy phase. When closing on to a bolted fault where all three-phase voltages are extremely low, the Zone 1 instantaneous elements may not operate. Time delayed operation would occur from either the Zone 3 offset element or the High Set Overcurrent. This is not acceptable and special precautions are necessary to ensure high-speed clearance for this condition.

The Switch-On-To-Fault feature ensures that for a short period of time after a CB is closed, the offset Zone 3 elements and the Overcurrent elements are allowed to trip at high speed.

1.6.2 Description of Operation

The mode of Switch-on-to-fault logic required can be selected as either AC SOTF or DC SOTF. AC SOTF utilises three-phase pole dead logic, based on measured current (i.e. an AC quantity), to determine the circuit breaker status. The DC SOTF uses an auxiliary contact (i.e. a DC quantity) on the CB closing handle to determine when the CB is being closed.

The SOTF output is automatically configured to operate the three-phase trip output. The LCTRIP can be mapped to one of the LED's and to any of the output contacts to give an alarm.

1.6.2.1 AC SOTF

The AC SOTF logic monitors the line current and voltage, and so it can only be used where the instrument transformers are placed on the line side of the circuit breaker. When the relay detects that the voltage and current are dead (i.e. voltage below 20% of the nominal, current below the SOTF O/C Operate Level) on all three phases, this will start the ACSOTFTIMER. This timer has a settable delay on pickup (the AC SOTF Pickup Delay) which is used to ensure that the circuit breaker has been switched out for maintenance.

This delay is set by default to 10,000ms, so the breaker must have been open for at least ten seconds before the SOTF logic is initiated. Once the logic has been initiated the relay can cause a SOTF trip in one of two ways;

1. If the measured current rises above the SOTF O/C Operate Level while the measured voltage remains below 20% of the nominal voltage, the Relay will trip instantaneously if the Zone 3 starter picks up. Once the measured voltage has increased above 20% of the nominal voltage, the ACSOTFTIMER will reset after a fixed time delay of 200ms and the Zone 3 starter will no longer cause an instantaneous trip.
2. If the measured current rises above the SOTF O/C Operate Level while the measured voltage remains below 20% of the nominal voltage, the Relay will trip after a fixed 25ms time delay. This delay is to prevent operation due to a race condition between the voltage and current reaching the "live" levels. Once the measured voltage has increased above 20% of the nominal voltage, the SOTF Overcurrent tripping criteria is removed instantaneously. This prevents the relay from tripping for high line charging currents.

This Overcurrent criterion is essential when a uni-directional Zone 3 is being used (i.e. not offset). In this case the zone 3 element will suffer from the same difficulties as Zones 1 and 2.

1.6.3 DC SOTF

The DC SOTF logic works in much the same way as the AC SOTF, but has been specifically designed for situations where the VTs are mounted on the busbar side of the line circuit breaker. This means that the voltage input to the relay cannot be used to supervise the position of the breaker.

A Status Input defined as DC SOTF Manual Close is connected to the Manual Close handle of the circuit breaker. This Status Input is triggered on the rising edge of the Manual Close signal, and for 400 ms after this signal the relay will allow instantaneous tripping of the Zone 3 element. A longer time delay is used for the DC SOTF logic (400ms rather than 200ms) because it needs to incorporate the closing time for the circuit breaker.

1.6.4 Settings

The settings menu for the SOTF function is contained in the AUX PROTECTION Menu and contains the following settings:

<i>Switch On To Fault</i>	Disable / Enable
<i>SOTF Mode</i>	AC SOTF / DC SOTF
<i>SOTF O/C Operate Level</i>	0.3..4 (0.3xIn)
<i>AC SOTF Pickup Delay</i>	10000ms

Status Inputs: **DC SOTF MANUAL CLOSE**
Relay Outputs: **SOTF OPERATED**

2 Auxiliary Functions

2.1 Fault Locator

2.1.1 Applications

The fault locator gives the operator an indication of the location of the fault. This information can be presented in three different formats which are a percentage of line length, or the distance in either miles or kilometres. This is selected in the menu function.

2.1.2 Description of Operation

The fault locator is programmed with the Positive Sequence Line Impedance. It is important that this value must be for the total length of the feeder and not the Zone 1 reach. The values must be in terms of secondary impedance. The secondary impedance per unit must also be entered. For example a 20km line may have a secondary impedance of 15 ohms. This would give a unit value of 0.75 ohms per kilometre using these values the fault locator would accurately measure the fault position.

The fault locator if enabled will measure for any general trip condition. While the fault is being calculated the relay fascia function keys are disabled for a few seconds.

2.1.3 Relay Settings

<i>Fault Locator</i>	Disable / Enable
<i>Pos Seq Line Impedance</i>	0.1 .. 250 (10)
<i>Sec'y Z+ per unit distance</i>	0.001..5 (0.5)
<i>Display Distance as</i>	Percent / Miles / Kilometres

Status Inputs: N/A
Relay Outputs: N/A

2.2 Trip Circuit Supervision

2.2.1 Description of Operation

The relay can monitor it's own trip circuit by assigning status inputs to *Trip Cct 1*, *Trip Cct 2* & *Trip Cct 3* (one for each of the three phases), Indication is then given instantaneously of trip circuit failure, should a fault be detected. The external connections for this feature are shown in Section 12.

2.2.2 Relay Settings

Status Inputs: **TRIP CCT Fail**
Relay Outputs: **TRIP CCT Fail**

2.3 High Set Overcurrent

2.3.1 Description of Operation

This is simply a DTL overcurrent element which works in parallel with the distance protection. Operation of this overcurrent element will result in a main distance trip.

2.3.2 Relay Settings

<i>High Set</i>	Disable / Enable
<i>HS Level</i>	0.1-35 x In (4x)
<i>HS Time Delay</i>	0..60000ms (0)

Status Inputs: N/A
Relay Outputs: **HIGH SET**

7SG163 Ohmega 300 Series

7SG163 Protection Relay

Document Release History

This document is issue 2010/02. The list of revisions up to and including this issue is:
Pre release

2010/02	Document reformat due to rebrand

The copyright and other intellectual property rights in this document, and in any model or article produced from it (and including any registered or unregistered design rights) are the property of Siemens Protection Devices Limited. No part of this document shall be reproduced or modified or stored in another form, in any data retrieval system, without the permission of Siemens Protection Devices Limited, nor shall any model or article be reproduced from this document unless Siemens Protection Devices Limited consent.

While the information and guidance given in this document is believed to be correct, no liability shall be accepted for any loss or damage caused by any error or omission, whether such error or omission is the result of negligence or any other cause. Any and all such liability is disclaimed.

Contents

1	Basic Schemes.....	3
1.1	Time Stepped Distance.....	3
1.2	Loss of Load.....	4
1.3	Reach Extension (Some models only).....	5
2	Schemes Incorporating a Signalling Channel.....	7
2.1	Permissive Underreach.....	7
2.2	Permissive Overreach Zone 1 – POR1.....	9
2.3	Permissive Overreach Zone 2 – POR2.....	10
2.4	Blocked Overreach (Some models only).....	12
2.5	Acceleration.....	13

1 Basic Schemes

1.1 Time Stepped Distance.

1.1.1 Scheme Operation

A TIME-STEPPED DISTANCE scheme is normally applied when there is no signalling available between relays. Generally, the Zone 1 elements are set to operate for faults up to 80% of the line length. The Zone 2 elements operate up to 120% of the line length after a time delay. The Zone 3 elements are set with a longer reach than the Zone 2 elements, and often have a degree of reverse reach (i.e. an offset characteristic) to provide a further level of back up protection. The Zone 3 time delay is set to be longer than the Zone 2 time delay.

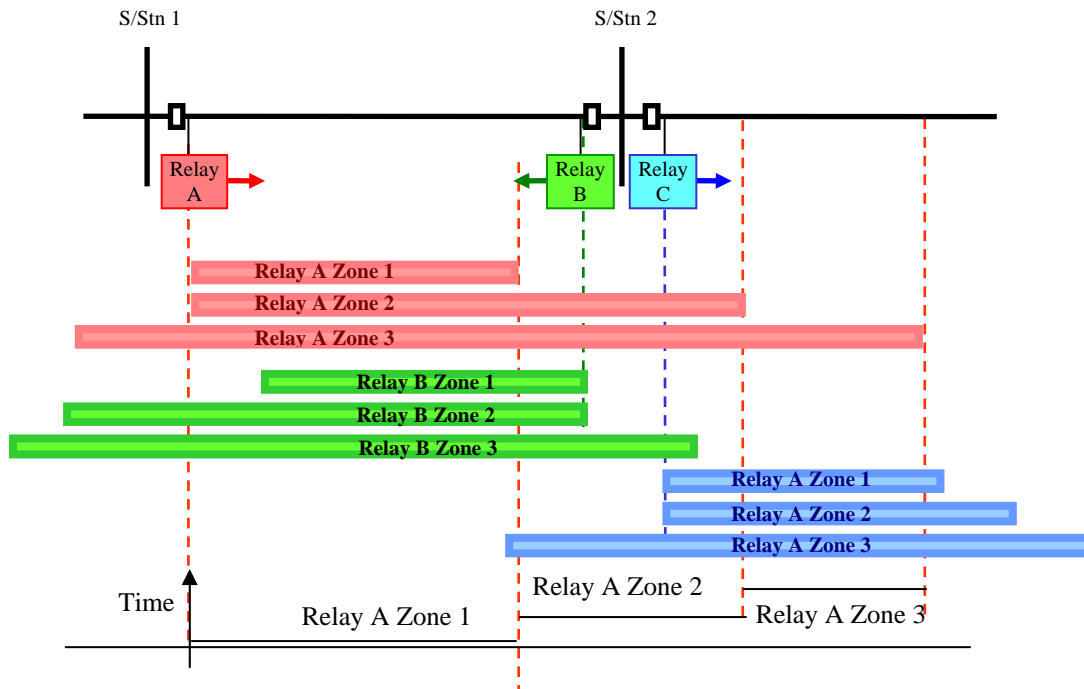

The disadvantage of such a scheme is that faults in the last 20% of the line are cleared after the Zone 2 time delay. This may be acceptable for lower voltage distribution systems, but for important circuits or higher voltage systems additional schemes are available to improve the tripping of the relay.

1.1.2 Settings

Distance Scheme

TIME-STEPPED

Status Inputs: N/A
Relay Outputs: N/A

1.2 Loss of Load.

1.2.1 Scheme Operation

The Loss of Load protection scheme is used to give faster fault clearance time for an end zone fault (i.e between the Zone 1 boundary and the line end) when there is no signalling channel available. This allows a faster clearance time than the time-delayed Zone 2 elements.

Consider a fault occurring near to the remote end, i.e outside of the Zone 1 reach, but within the line length. In a normal time stepped distance scheme, the remote end relay would trip in Zone 1 time, and the local end relay would trip after the Zone 2 time delay. The Loss of Load scheme monitors the current in the healthy phases and can remove the Zone 2 time delay, speeding up the local end trip, when the remote end trip occurs.

If the relay detects a drop in current in one or two phases below the *Loss of Load Level*, with the current on the remaining phases above this level, it will remove the time delay from zone 2, for a fixed time delay (the *LOL Time Limit*) to allow the relay to trip instantaneously. This will allow the relay to trip more quickly for single or double phase faults, but will not affect operation for three phase faults.

A short time delay (typically 20ms), known as the *Loss of Load Pole Scatter Delay* or the *LOL CB Op Delay* is introduced to prevent the Loss of Load feature picking up during normal breaker operation.

1.2.2 Settings

The Loss Of Load function (LOL) is made active by selecting the scheme in the scheme selection menu. If a conventional scheme is selected and a communications failure occurs then a group setting change could be used to switch the scheme on until the communications is restored.

<i>Distance Scheme</i>	LOSS OF LOAD
<i>LOL Level</i>	0.1..0.9 (0.5x In)
<i>LOL CB Op Delay or LOL Pole Scatter Delay</i>	0..50 (20ms)
<i>LOL Time Limit</i>	0..60000 (40ms)

Status Inputs: N/A
Relay Outputs: **AIDED TRIP, LOSS OF LOAD**

1.3 Reach Extension (Some models only).

This scheme is only available in relays with built-in autoreclose.

1.3.1 Scheme Operation

The Reach Extension is designed to be used in conjunction with an autoreclose system.

The Zone 1 elements within the relay have two settings. The standard Zone 1 settings are set as for the time-stepped distance scheme (i.e. 80% of the total line length). Zone 1 X settings are set to overreach the line length (usually these are set to the same value as the zone 2 setting)

When the reach extension scheme is implemented, the relay will use the extended zone 1 reach for tripping. The relay will trip and attempt to auto-reclose. After the CB has tripped and reclosed, the relay will use the standard (underreaching) Zone 1 reach for tripping. Consider a transient fault (i.e. a fault which is removed by tripping and auto-reclosing) in the last 20 % of the line, as shown in the diagram below. The overreaching Zone 1 will trip and reclose for this fault, and since it is transient, it will be cleared. A permanent fault will be cleared after the Zone 2 time on the second trip. Since the majority of faults are transient in nature, this will allow transient faults to be cleared more quickly.

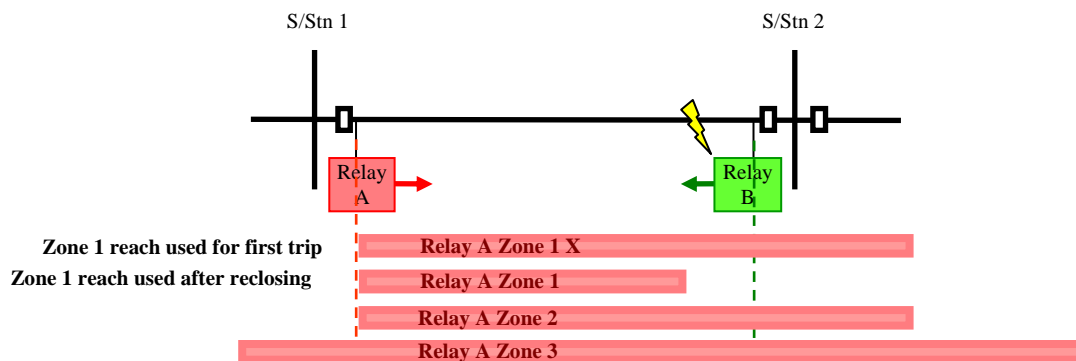

The disadvantage of this scheme is that since the extended Zone 1 reach is an overreaching Zone, it may operate for faults in the next line section. However, when the relay has reclosed, the Zone 1 reach will be reduced so the relay will trip after the Zone 2 time, allowing the correct relay to trip in Zone 1 after reclosing, if the fault is permanent. Overall this will increase the amount of circuit breaker operations on the system, and thus the amount of circuit breaker maintenance required, but it will improve clearance of transient faults

When a status input assigned *Block Reach Extension* is energised will the relay will use the normal Zone 1 reach.

The extended zone 1 reach will be active regardless of whether the autorecloser is on or out of service. It is advised that the *Block Reach Extension* status input is energised whenever the autorecloser is out of service. If the relay features an internal autorecloser, a normally closed contact should be assigned to Autorecloser in Service and connected back into the "Block Reach Extension" status input.

1.3.2 Settings

Distance Scheme

Z1 Extension

Zone 1 X PF Impedance Reach

Zone 1 X PF Resistance Reach

Zone 1 X PF Reactance Reach

Zone 1 X EF Impedance Reach

Zone 1 X EF Resistance Reach

Zone 1 X EF Reactance Reach

**REACH EXTENSION
ENABLED**

These are the settings used by the relay for the first trip

Status Inputs: **BLOCK REACH EXT.**

Relay Outputs: N/A

2 Schemes Incorporating a Signalling Channel

Where a signalling channel is available between ends, the coverage of the relays can be improved. When these Protection Schemes are used, the Zone 1, 2 and 3 are arranged to trip as in the time stepped distance scheme. In addition to this, the relay is also capable of carrying out what is known as a “Carrier Aided Trip”, where the time delay on one of the Zones is removed when the conditions at the remote end, as indicated by the signalling channel meet certain criteria.

The distance protection signalling schemes use the relay outputs *Signal Send 1* and status input *Signal Received 1* for the signalling channel. It is possible to configure these channels with delay using the settings SS pickup, SS Dropoff and SR Dropoff.

2.1 Permissive Underreach.

2.1.1 Scheme Operation

Typically (as for the time stepped scheme) the Zone 1 is set to 80% of the line length, Zone 2 to 120% of the line length and Zone 3 as delayed back up protection to cover at least the longest adjacent line.

The fault must be in the zone between the two relays (i.e. on the line section) if;

- Both Local and Remote Zone 1 elements operate, or
- Remote end Zone 1 operates AND local Zone 3 element operates.

This is shown in the diagram below:

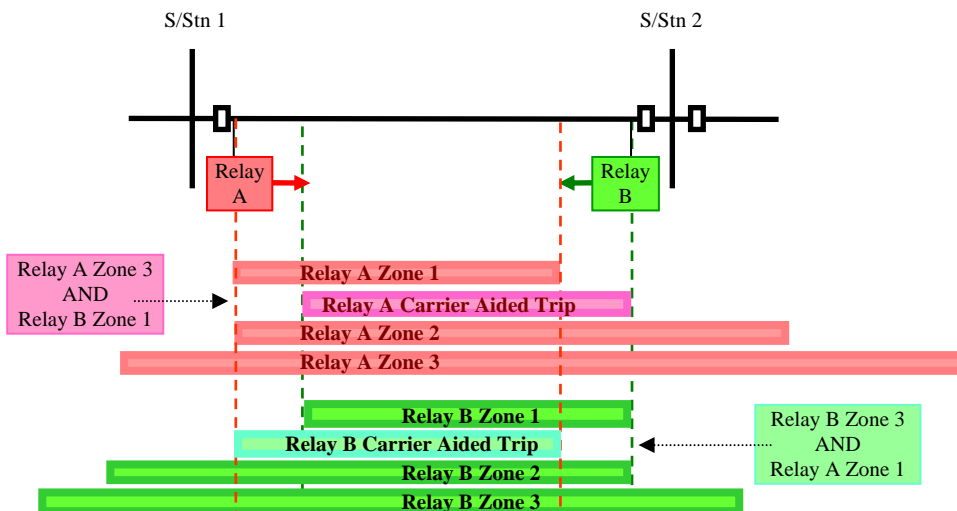

The relay is arranged to send a signal when its Zone 1 picks up.

The relay will trip instantaneously for a Zone 1 fault. If a signal is received from the remote end, the time delay will be removed from the Zone 3 element, allowing it to trip instantaneously. The name of the scheme comes from the fact that a Permissive signal is being sent by the Underreaching Zone 1.

Where the signalling equipment has an output which indicates that the signalling channel is out of service, this can be connected to a Status Input called *Carrier Recv Guard*. On energisation of this status input the relay will revert to a time stepped distance scheme.

2.1.2 Settings.

<i>Distance Scheme</i>	PUR
<i>SS Dropoff</i>	0..60000 (1ms)
<i>SR Dropoff</i>	0..60000 (1ms)

Status Inputs: **CARRIER RECV GUARD, SIGNAL RECEIVE 1**

Relay Outputs: **AIDED TRIP, SIGNAL SEND 1**

2.2 Permissive Overreach Zone 1 – POR1.

2.2.1 Scheme Operation

This scheme differs from the other relay schemes, in that it requires that the Zone 1 element to be set with a time delay. Typically the Zone 1 is set to 120% of the line length, Zone 2 to 120% of the line length and Zone 3 as delayed back up protection to cover at least the longest adjacent line. The Zone 1 time delay is usually set the same as the Zone 2 time delay.

The Zone 1 elements are arranged to overreach and the relay is arranged to send a Permissive signal send when any Overreaching Zone 1 element operates. When a signal is received from the remote end the relay will remove the Zone 1 time delay allowing the relays at both ends of the line to trip after a small time delay for an in-zone fault. Relay operation can be seen the diagram below;

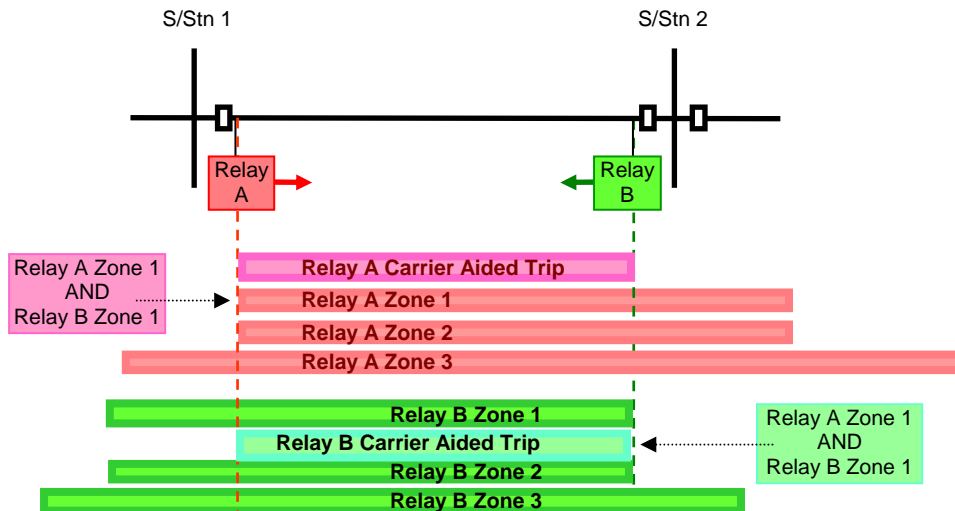

Where the signalling equipment has an output which indicates that the signalling channel is out of service, this can be connected to a Status Input called *Carrier Recv Guard*. On energisation of this status input the relay will revert to a time stepped distance scheme.

2.2.2 Weak End Infeed

If one end of the line has little or no source of fault current, the Relay may not see enough current for any of its Zones to pick up. However a Weak Infeed trip will be forced if;

- No Distance elements have picked up AND
- A permissive signal is received from the remote end AND
- There is a residual voltage present AND
- The local CB is closed.

2.2.3 Settings

<i>Distance Scheme</i>	POR1
<i>SS Dropoff</i>	0..60000 (1ms)
<i>SR Dropoff</i>	0..60000 (1ms)
<i>POR Weak Infeed Tripping</i>	Enabled/ Disabled
<i>POR Current Rev Reset</i>	0..60000 (200ms)
<i>POR CB Echo Pulse</i>	0..60000 (250ms)

Status Inputs: **CARRIER RECV GUARD, SIGNAL RECEIVE 1**

Relay Outputs: **AIDED TRIP, SIGNAL SEND 1, POR WEAK INFEED**

2.3 Permissive Overreach Zone 2 – POR2.

2.3.1 Scheme Operation

Typically (as for the time stepped and PUR schemes) the Zone 1 is set to 80% of the line length, Zone 2 to 120% of the line length and Zone 3 as delayed back up protection to cover at least the longest adjacent line. Zone 1 has no time delay, Zone 2 has a time delay, and the Zone 3 has a larger time delay.

The fault must be in the region between the two relays (i.e. on the line section) if;
Zone 1 element operates, or

Remote end Zone 2 operates AND local Zone 2 element operates.

This is shown in the diagram below:

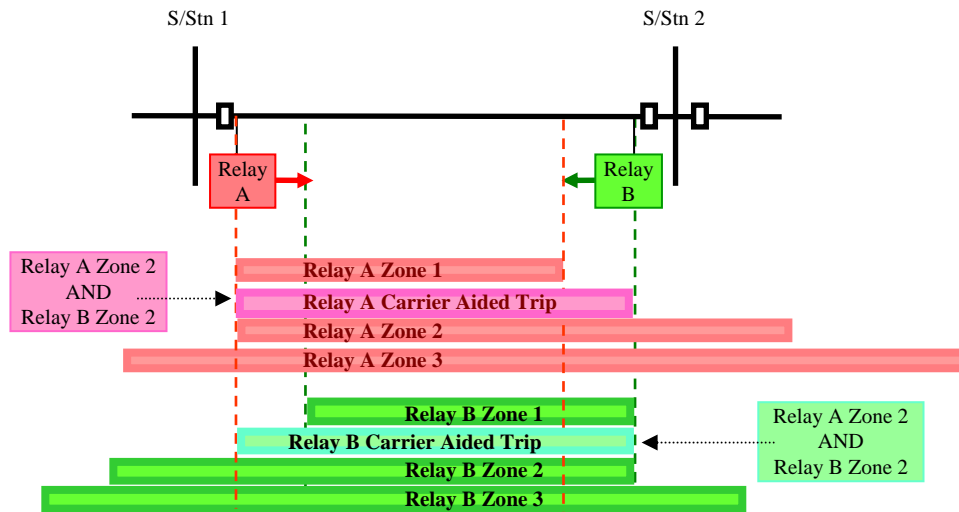

The relay is arranged to send a signal when its Zone 2 picks up.

The relay will trip instantaneously for a Zone 1 fault. If a signal is received from the remote end, the time delay will be removed from the Zone 2 element, allowing it to trip instantaneously. The name of the scheme comes from the fact that a Permissive signal is being sent by the Overreaching Zone 2.

This scheme may be used if the Zone 1 reach does not give sufficient resistive coverage, and may be useful on short lines.

Where the signalling equipment has an output which indicates that the signalling channel is out of service, this can be connected to a Status Input called *Carrier Recv Guard*. On energisation of this status input the relay will revert to a time stepped distance scheme.

2.3.2 Weak End Infeed

If one end of the line has little or no source of fault current, the Relay may not see enough current for any of its Zones to pick up. However a Weak Infeed trip will be forced if;

- No Distance elements have picked up AND
- A permissive signal is received from the remote end AND
- There is a residual voltage present AND
- The local CB is closed.

2.3.3 Settings

<i>Distance Scheme</i>	POR2
<i>SS Dropoff</i>	0..60000 (1ms)
<i>SR Dropoff</i>	0..60000 (1ms)
<i>POR Weak Infeed Tripping</i>	Enabled/ Disabled
<i>POR Current Rev Reset</i>	0..60000 (200ms)
<i>POR CB Echo Pulse</i>	0..60000 (250ms)

Status Inputs: **CARRIER RECV GUARD, SIGNAL RECEIVE 1**

Relay Outputs: **AIDED TRIP, SIGNAL SEND 1, POR WEAK INFEED**

2.4 Blocked Overreach (Some models only)

This scheme is only available on relays with four zones of protection, because a reverse-looking element is required to allow the sending of a blocking signal.

2.4.1 Scheme Operation

The fault must be in the region between the two relays (i.e. on the line section) if; The overreaching Zone 2 element operates and a reverse looking zone at the remote end has **not** operated. This can be seen in the diagram below;

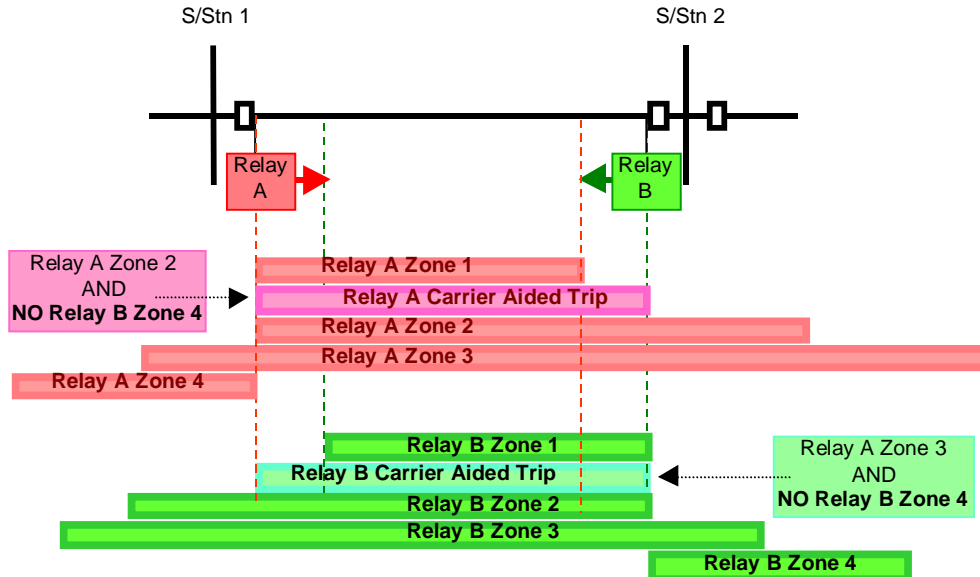

When the Zone 2 instantaneous element picks up, the relay waits for a “blocking signal” to be received. If no blocking signal is received during a set time delay (known as the Permissive Trip Time) the relay will carry out a “Carrier Aided Trip”. If, during this time delay, a blocking signal is received, the Zone 2 time delay will remain in place, and the relay will carry out a Zone 2 trip after the Zone 2 Time delay.

If the fault is in the last section of the line (i.e. outside the Zone 1 reach) the Zone 2 element will operate, but the remote end relay Zone 4 element will not see the fault. Thus, no blocking signal will be sent, and the relay will carry out a “Carrier Aided Trip” after the *Permissive Trip Time*.

Obviously when applying this scheme the reverse reach of the Zone 4 element must be further than the overreach of the remote end Zone 2 element.

Where the signalling equipment has an output which indicates that the signalling channel is out of service, this can be connected to a Status Input called *Carrier Recv Guard*. On energisation of this status input the relay will revert to a time stepped distance scheme.

The scheme also incorporates an *Unstabilise Relay* status input which can be used for intertripping. Energisation of this status input will prevent a Blocking signal send when a reverse fault is detected in Zone 4.

2.4.2 Settings

Distance Scheme	BOR
Permissive Trip Time	0..60000 (1ms)
SS Dropoff	0..60000 (1ms)
SR Dropoff	0..60000 (1ms)

Status Inputs: **BLOCK MODE INHIBIT, CARRIER RECV GUARD, UNSTABILISE RELAY**

Relay Outputs: N/A

2.5 Acceleration

2.5.1 Scheme Operation

This is similar to the Permissive Undereach scheme except for the fact that receipt of a permissive signal removes the time delay from the Zone 2 element instead of the Zone 3 Element. The scheme is shown in the diagram below;

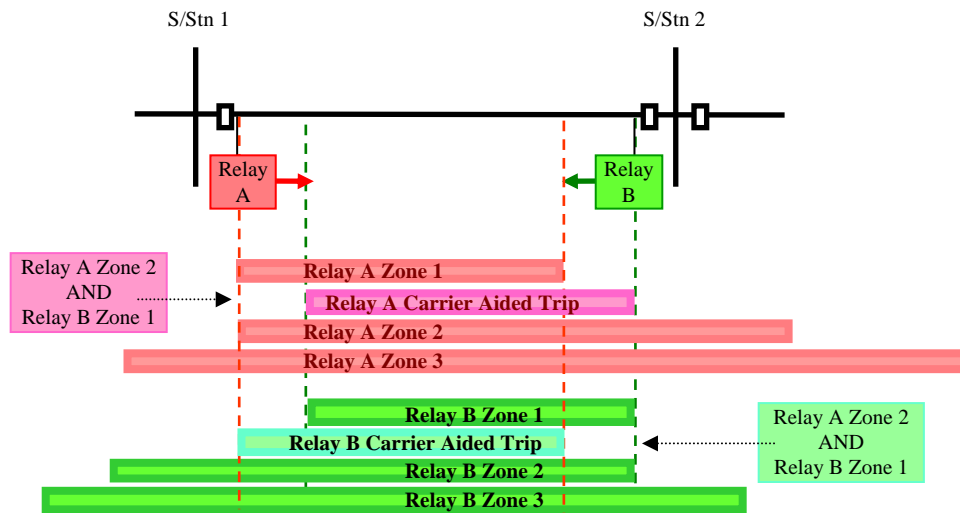

2.5.2 Settings

<i>Distance Scheme</i>	ACCELERATION
<i>SS Dropoff</i>	0..60000 (1ms)
<i>SR Dropoff</i>	0..60000 (1ms)

Status Inputs: **CARRIER RECV GUARD, SIGNAL RECEIVE 1**

Relay Outputs: **AIDED TRIP, SIGNAL SEND 1**

7SG1635 Ohmega 315

Protection Relays

Document Release History

This document is issue 2010/02. The list of revisions up to and including this issue is:
Pre release

2010/02	Document reformat due to rebrand

Software Revision History

01-12-2006	2615H80034R5	
------------	--------------	--

The copyright and other intellectual property rights in this document, and in any model or article produced from it (and including any registered or unregistered design rights) are the property of Siemens Protection Devices Limited. No part of this document shall be reproduced or modified or stored in another form, in any data retrieval system, without the permission of Siemens Protection Devices Limited, nor shall any model or article be reproduced from this document unless Siemens Protection Devices Limited consent.

While the information and guidance given in this document is believed to be correct, no liability shall be accepted for any loss or damage caused by any error or omission, whether such error or omission is the result of negligence or any other cause. Any and all such liability is disclaimed.

Contents

1	Menu Settings	3
2	Settings Walkthrough	13
2.1	System Config Menu	13
2.2	Distance Protection Menu	14
2.3	Aux Protection Menu	18
2.4	Auto Reclose Menu	21
2.5	Sync Menu	23
2.6	Reylogic Config Menu	24
2.7	Status Config Menu	25
2.8	Output Config Menu	27
2.9	Output Operate Time Menu	31
2.10	LED Configuration Menu	31
2.11	Communications Menu	31
2.12	CB Maintenance Menu	32
2.13	Data Storage Menu	32
2.14	Fault Locator Menu	33

1 Menu Settings

Software Version

2615H80034R5

SYSTEM CONFIG MENU

Setting	Range	Default	
Alternate Setting Group	1 – 8	1	
CT Ratio	0:1..5000:5	2000 1	
VT Ratio	1000:90..600000:130	132000 110	
CVT in use	NO, YES	NO	
Clock Sync. From Status	Disabled, Seconds, Minutes	Minutes	
Default Screens Timer	Off, 1, 2, 5, 10, 15, 30, 60 mins	60 min	
Backlight timer	Off, 1, 2, 5, 10, 15, 30, 60 mins	5 min	
Change Password	4-Digit Password	NONE	
Relay Identifier	16 Character String	OHMEGA-315-50	

DISTANCE PROTECTION MENU

Setting	Range	Default	
Active Scheme	<i>Time stepped</i> , PUR, POR1, POR2, Reach Extension, Loss Of Load, Acceleration, BOR	PUR	
Carrier Guard	Disabled, Enabled	Enabled	
CT Secondary	1A, 2A, 5A	1A	
Line Angle	0 – 90° in steps of 5°	75 deg	
EF Comp Z0/Z1 ratio	0 – 10	2.5	
EF Comp Z0 angle	0-355° in steps of 5°	75 deg	
Reactive Drop Angle	-20° .. 20° in steps of 1°	-3 deg	
Z1 Extension	Disabled, Enabled	Enabled	
Z1 Phase Fault	Disabled, Enabled	Enabled	
Z1 PF Impedance	0.1 – 250 Ω	8 Ω	
Z1X PF Impedance	0.1 – 250 Ω	12 Ω	
Z1 PF Time Delay	0 – 10000 ms	0ms	
Z1 Earth Fault	Disabled, Enabled	Enabled	
Z1 EF Type	Fwd Mho, Fwd Quad	Fwd Mho	
Z1 EF Impedance	0.1 – 250 Ω	8 Ω	
Z1 EF Resistance	0.1 – 250 Ω	4 Ω	
Z1 EF Reactance	0.1 – 250 Ω	8 Ω	
Z1X EF Impedance	0.1 – 250 Ω	12 Ω	
Z1X EF Resistance	0.1 – 250 Ω	6 Ω	
Z1X EF Reactance	0.1 – 250 Ω	12 Ω	
Z1 EF Time Delay	0 –10000 ms	0ms	
Z2 Phase Fault	Disabled, Enabled	Enabled	
Z2 PF Impedance	0.1 – 250 Ω	16 Ω	
Z2 PF Time Delay	0 –10000 ms	1000ms	
Z2 Earth Fault	Disabled, Enabled	Enabled	
Z2 EF Type	Fwd Mho, Fwd Quad	Fwd Mho	
Z2 EF Impedance	0.1 – 250 Ω	16 Ω	
Z2 EF Resistance	0.1 – 250 Ω	8 Ω	
Z2 EF Reactance	0.1 – 250 Ω	16 Ω	
Z2 EF Time Delay	0 – 10000ms	1000ms	
Z3 Phase Fault	Disabled, Enabled	Enabled	
Z3 PF Type	Fwd Mho, Rev Mho, Offset Mho	Offset Mho	
Z3 PF Impedance (Fwd)	0.1 – 250 Ω	24Ω	

Z3 PF Impedance (Rev)	0.1 – 250 Ω	8Ω	
Z3 PF Time Delay	0 – 10000ms	2000ms	
Z3 Earth Fault	Disabled, Enabled	Enabled	
Z3 EF Type	Fwd Mho, Rev Mho, Offset Mho Fwd Quad, Rev Quad, Offset Quad	Offset Mho	
Z3 EF Impedance (Fwd)	0.1 – 250 Ω	24 Ω	
Z3 EF Resistance (Fwd)	0.1 – 250 Ω	12 Ω	
Z3 EF Reactance (Fwd)	0.1 – 250 Ω	24 Ω	
Z3 EF Impedance (Rev)	0.1 – 250 Ω	8 Ω	
Z3 EF Resistance (Rev)	0.1 – 250 Ω	4 Ω	
Z3 EF Reactance (Rev)	0.1 – 250 Ω	8 Ω	
Z3 EF Time Delay	0 – 10000ms	2000ms	
Z4 Phase Fault	Disabled, Enabled	Enabled	
Z4 PF Impedance	0.1 – 250 Ω	8 Ω	
Z4 PF Time Delay	0 – 10000ms	0ms	
Z4 Earth Fault	Disabled, Enabled	Enabled	
Z4 EF Type	Rev Mho, Rev Quad	Rev Mho	
Z4 EF Impedance	0.1 – 250 Ω	8 Ω	
Z4 EF Resistance	0.1 – 250 Ω	4 Ω	
Z4 EF Reactance	0.1 – 250 Ω	8 Ω	
Z4 EF Time Delay	0 – 10000ms	0ms	
POR Weak Infeed Tripping	Disabled, Enabled	Disabled	
WI Voltage Level	5-85v	54v	
POR Current Rev Reset	0 – 60000 ms	200ms	
POR CB Echo Pulse	0 – 60000 ms	250ms	
LOL Level	0.1 – 0.9	0.5x In	
LOL CB Op Delay	0 – 60000 ms	20ms	
LOL Time Limit	0 – 60000 ms	40ms	
Power Swing Detector	Disabled, Enabled	ENABLE	
PSD Zone blocking	4 Bit Binary	-111	
PSD Shape	Circular, Rectangular	CIRCULAR	
PSD Blinders	Disabled, Enabled	DISABLE	
PSD Inner Fwd Impedance	0.1 – 250 Ω	24 Ω	
PSD Inner Rev Impedance	0.1 – 250 Ω	8 Ω	
PSD Inner Fwd Blinder	0.1 – 250 Ω	16 Ω	
PSD Inner Rev Blinder	0.1 – 250 Ω	16 Ω	
PSD Outer Multiplier	1.05 – 2	1.5 x	
PSD Transit Time	0 – 1000 ms	50ms	

AUX PROTECTION MENU

Setting	Range	Default	
High Set	Disabled, Enabled	Enabled	
HS Level	0.1 – 35	4x In	
HS Time Delay	0 – 1000	0ms	
SEF Protection	Disabled, Enabled	Enabled	
SEF Current Setting	0.02 – 0.95	0.1x In	
SEF Alarm Delay	0.0 – 60s	1s	
SEF Trip Delay	0.0 – 60s	1s	
Overvoltage Prot.	Disabled, Enabled	Enabled	
OV Alarm Level	1.00 – 1.50xV _N	1.07 x V _N	
OV Alarm Time Delay	0 – 1000 ms	0ms	
OV Trip Level	1.00 – 1.50xV _N	1.15 x V _N	
OV Trip Time Delay	0 – 1000 ms	0ms	
Undervoltage Prot.	Disabled, Enabled	Enabled	

UV Block Level	Disabled, 1 – 60.0 V	3V	
UV1 Level	5.0 – 80.0 V	55V	
UV1 Time Delay	0.00 – 60s	5s	
UV1 Hysteresis	1 – 90 %	2%	
UV1 O/P Phases	(Any 1All)	Any 1	
UV1 Tripping	Disabled, Enabled	Disabled	
UV2 Level	5.0 – 80.0 V	55V	
UV2 Time Delay	0.00 – 60s	10s	
UV2 Hysteresis	1 – 90 %	2%	
UV2 O/P Phases	Any 1, All	Any 1	
UV2 Tripping	Disabled, Enabled	Disabled	
SOTF	Disabled, Enabled	Enabled	
SOTF Mode	AC SOTF, DC SOTF	AC SOTF	
SOTF O/C Operate Level	0.3 – 4 x In	0.3 x In	
AC SOTF Pickup Delay	0 – 60000 ms	10000ms	
Min AUX DC SOTF Dead Time	0 – 60000 ms	10000ms	
VT Supervision	Disabled, Enabled	Enabled	
VTS Latched Operation	Disabled, Enabled	Enabled	
VTS Mode	Alarm Only, Alarm & Inhibit	Alarm & Inhibit	
VTS Phase Fault Inhibit	Disabled, Enabled	Enabled	
VTS Input Source	RES I/V, NPS I/V	RES I/V	
VTS Ires Level	0.05 – 4 x In	0.3x In	
VTS Vop Level	1 – 100V	20V	
VTS Alarm Op. Delay	0 – 60000 ms	100ms	
VTS Latch Op. Delay	0 – 60000 ms	5000ms	
OC Guard	Disabled, Enabled	Enabled	
OC Guard Setting	0.01-25	1.5xIn	
OC Guard Delay	0-864000s	1s	
OC Guard Z1	OCG Z1 Disabled, OCG Z1 Enabled	OCG Z1 Disabled	
OC Guard Z2	OCG Z2 Disabled, OCG Z2 Enabled	OCG Z1 Disabled	
OC Guard Z3	OCG Z3 Disabled, OCG Z3 Enabled	OCG Z1 Disabled	
OC Guard Z4	OCG Z2 Disabled, OCG Z2 Enabled	OCG Z1 Disabled	
Fwd DEF Protection	Disabled, Enabled	Enabled	
DEF Active Scheme	DEF POR, DEF BOR, DEF Direct Trip	DEF POR	
Fwd DEF Char Angle	-95° ..95°	-45deg	
Fwd DEF Setting	0.1 – 2.5	1x In	
Fwd DEF Char	IEC – NI, VI, EI, LTI : ANSI – MI, VI, EI DTL	IEC-NI	
Fwd DEF Time Mult (IEC/ANSI)	0.025 – 1.6	1	
Fwd DEF Delay (DTL)	INST, 0.01 – 20	5s	
Fwd DEF Reset	(ANSI) DECAYING, 1-60	INST	
Rev DEF Protection	Disabled, Enabled	Enabled	
Rev DEF Char Angle	-95° ..95°	-45deg	
Rev DEF Setting	0.1– 2.5	1x In	
Rev DEF Char	IEC – NI, VI, EI, LTI : ANSI – MI, VI, EI DTL	IEC-NI	
Rev DEF Time Mult (IEC/ANSI)	0.025 – 1.6	1	
Rev DEF Delay (DTL)	INST, 0.01 – 20	5s	
Rev DEF Reset	(ANSI) DECAYING, 1-60	INST	
DEF WI Res OV Setting	0 – 20	1V	
DEF Current Rev Reset	0 – 60000	200ms	
CB Echo Pulse Width	0 – 60000	250ms	
Trip Circuit Fail	Disabled, Enabled	Disabled	

AUTORECLOSE MENU

Setting	Range	Default	
A/R In Service	In, Out	Out	
Dead Bar Charge	Disabled, Enabled	Disabled	
Dead Line Charge	Disabled, Enabled	Disabled	
Dead Line & Dead Bar Close	Disabled, Enabled	Disabled	
Check Sync Close	Disabled, Enabled	Enabled	
Unconditional Close	Disabled, Enabled	Disabled	
Manual Close DBC	Disabled, Enabled	Disabled	
Manual Close DLC	Disabled, Enabled	Disabled	
Manual Close DLDB	Disabled, Enabled	Disabled	
Manual Close CS	Disabled, Enabled	Enabled	
Deadtime	0 – 900	5s	
Live Line Check	Disabled, Enabled	Enabled	
Check Sync During Deadtime	Disabled, Enabled	Enabled	
VT Fail Lockout	Disabled, Enabled	Disabled	
CB Close Pulse	0.2 – 20s	2s	
Reclaim Time	OFF, 1 – 600	5s	
Dead Line Charge Delay	0 – 60s	0s	
Dead Bar Charge Delay	0 – 60s	0s	
Reclose Blocked Delay	0 – 600s	60s	
Sync Close Delay	0 – 60s	30s	
Sequence Fail Timer	Off, 1 – 600	Off	
CB Fail To Open Delay	50 – 2000	100ms	
Minimum LO Timer	0 – 60	2s	
Reset LO By Timer	Disabled, Enabled	Disabled	
Z2 AR Start	Disabled, Enabled	Disabled	
Z3 AR Start	Disabled, Enabled	Disabled	
DEF AR Start	Disabled, Enabled	Disabled	
DEF Aided AR Start	Disabled, Enabled	Disabled	
Fault Type AR Start	2P/1P, All	2P/1P	

SYNC MENU

Setting	Range	Default	
Sync Connection	Phase B-Earth, Phase A-Phase B	Phase B-Earth	
Check Sync Vnom	63.5, 110V	63.5V	
Bus : Dead Live	5-150:10-155	20:90%	
Line: Dead Live	5-150:10-155	20:90%	
Bus Undervolts	OFF, 5 – 150	90%	
Line Undervolts	OFF, 5 – 150	90%	
Voltage Differential	OFF, 1 – 100	10%	
Split Angle	OFF, 95 – 175	175deg	
MC Split Action	System Sync, Check Sync	System Sync	
ARC Split Action	System Sync, Lockout	Lockout	
Check Sync Angle	5 – 90	20deg	
Check Sync Slip	OFF, 10 – 2000	50mHz	
Check Sync Timer	OFF, 0.1 – 100	OFF	
System Sync Angle	5 – 90	10deg	
Sys Sync Slip Frequency	OFF, 10 – 2000	125mHz	
System Sync Timer	OFF, 0.1 – 100	OFF	

REYLOGIC CONFIG MENU

Setting	Range	Default	
SR Dropoff	0 – 60000ms	1 ms	
SS Dropoff	0 – 60000ms	1 ms	
Permissive Trip Time	0 – 60000ms	20 ms	
SR2 Dropoff	0 – 60000ms	1 ms	
SS2 Dropoff	0 – 60000ms	1 ms	
DEF Perm Trip Time	0 – 60000ms	20 ms	
Timer 1 Pickup Delay	0 – 60000ms	1 ms	
Timer 1 Dropoff Delay	0 – 60000ms	0 ms	
Timer 2 Pickup Delay	0 – 60000ms	1 ms	
Timer 2 Dropoff Delay	0 – 60000ms	0 ms	
Counter 1 Target	0 – 60000	1	
Counter 2 Target	0 – 60000	1	

STATUS CONFIG MENU

Setting	Range	Default	
Signal Receive 1	(39 Character String)	1	
Carrier Guard	(39 Character String)	NONE..	
Unstabilise Relay	(39 Character String)	NONE..	
Block Mode Inhibit	(39 Character String)	NONE..	
Block Reach Ext	(39 Character String)	NONE..	
Signal Receive 2	(39 Character String)	2	
Block DEF	(39 Character String)	16....	
DEF Block Mode Inhib	(39 Character String)	NONE..	
DC SOTF Manual Close	(39 Character String)	8	
Start AUX DC SOTF	(39 Character String)	NONE..	
VT Circuits Isolated	(39 Character String)	NONE..	
Trigger Storage	(39 Character String)	NONE..	
Increment Trip Count	(39 Character String)	NONE..	
Reset Total Trip Cnt	(39 Character String)	NONE..	
Reset Delta Trip Cnt	(39 Character String)	NONE..	
Reset Total CB Close	(39 Character String)	NONE..	
Use Alt Setting Grp	(39 Character String)	NONE..	
Block Reclose	(39 Character String)	7	
A/R Out	(39 Character String)	13....	
A/R In	(39 Character String)	12....	
Go Direct To Lockout	(39 Character String)	15....	
Trip And Reclose	(39 Character String)	14....	
External A/R Start	(39 Character String)	6	
Reset Lockout	(39 Character String)	5	
Sync Override	(39 Character String)	NONE..	
Manual Sync Override	(39 Character String)	NONE..	
CB Phase A Closed	(39 Character String)	3	
CB Phase B Closed	(39 Character String)	3	
CB Phase C Closed	(39 Character String)	3	
CB Phase A Open	(39 Character String)	4	
CB Phase B Open	(39 Character String)	4	
CB Phase C Open	(39 Character String)	4	
Manual Close	(39 Character String)	NONE..	
Reset Delta CB Close	(39 Character String)	NONE..	
Input 1	(39 Character String)	1	
Input 2	(39 Character String)	2	

Input 3	(39 Character String)	3	
Input 4	(39 Character String)	4	
Input 5a	(39 Character String)	NONE..	
Input 5b	(39 Character String)	NONE..	
Input 5c	(39 Character String)	NONE..	
Input 5d	(39 Character String)	NONE..	
Input 6a	(39 Character String)	NONE..	
Input 6b	(39 Character String)	NONE..	
Input 6c	(39 Character String)	NONE..	
Input 6d	(39 Character String)	NONE..	
Timer 1	(39 Character String)	NONE..	
Timer 2	(39 Character String)	NONE..	
Counter 1 Count	(39 Character String)	NONE..	
Counter 1 Reset	(39 Character String)	NONE..	
Counter 2 Count	(39 Character String)	NONE..	
Counter 2 Reset	(39 Character String)	NONE..	
Trip Circuit Fail	(39 Character String)	NONE..	
Clock Sync.	(39 Character String)	NONE..	

OUTPUT CONFIG MENU

Setting	Range	Default	
Protection Healthy	(39 Character String)	1	
Signal Send 1	(39 Character String)	6	
POR Weak Infeed	(39 Character String)	NONE..	
DEF POR Weak Infeed	(39 Character String)	NONE..	
DEF Aided Trip	(39 Character String)	NONE..	
Signal Send 2	(39 Character String)	7	
DEF Protection	(39 Character String)	17....	
DEF Rev Protection	(39 Character String)	NONE..	
Sig Recvd 2 Flag	(39 Character String)	NONE..	
UV1 Alarm	(39 Character String)	NONE..	
UV2 Alarm	(39 Character String)	NONE..	
UV Trip	(39 Character String)	NONE..	
SOTF Operated	(39 Character String)	12....	
VTS Alarm	(39 Character String)	11....	
Trip Output	(39 Character String)	4,14	
Trip Reset	(39 Character String)	NONE..	
Phase A Fault	(39 Character String)	NONE..	
Phase B Fault	(39 Character String)	NONE..	
Phase C Fault	(39 Character String)	NONE..	
Earth Fault	(39 Character String)	NONE..	
Zone 1	(39 Character String)	8	
Zone 2	(39 Character String)	9	
Zone 3	(39 Character String)	10....	
Zone 4	(39 Character String)	NONE..	
Aided Trip	(39 Character String)	NONE..	
Sig Recvd 1 Flag	(39 Character String)	NONE..	
Carrier Guard	(39 Character String)	NONE..	
Power Swing Alarm	(39 Character String)	15....	
Delta Trip Cnt Alarm	(39 Character String)	NONE..	
Total Trip Cnt Alarm	(39 Character String)	NONE..	
High Set	(39 Character String)	13....	
Overvoltage Alarm	(39 Character String)	NONE..	

Overvoltage	(39 Character String)	20....	
SEF Alarm	(39 Character String)	NONE..	
SEF Protection	(39 Character String)	19....	
Close Pulse	(39 Character String)	5	
Trip Relay Reset	(39 Character String)	NONE..	
Lockout	(39 Character String)	16....	
A/R Out of Service	(39 Character String)	NONE..	
A/R In Service	(39 Character String)	NONE..	
A/R In Progress	(39 Character String)	18....	
Live Line	(39 Character String)	NONE..	
Live Bus	(39 Character String)	NONE..	
In Sync	(39 Character String)	NONE..	
CB Open	(39 Character String)	NONE..	
CB Closed	(39 Character String)	NONE..	
CB Failed To Close	(39 Character String)	NONE..	
System Split	(39 Character String)	NONE..	
Successful Close	(39 Character String)	NONE..	
CB Failed to Open	(39 Character String)	NONE..	
Check Sync Start	(39 Character String)	NONE..	
Sync In Prog Flag	(39 Character String)	NONE..	
Close Onto Fault	(39 Character String)	NONE..	
Delta CB Count Alarm	(39 Character String)	NONE..	
Total CB Count Alarm	(39 Character String)	NONE..	
CB Not In Ser Alarm	(39 Character String)	NONE..	
CB Memory	(39 Character String)	NONE..	
A/R Not Allowed	(39 Character String)	NONE..	
Input 1 Operated	(39 Character String)	NONE..	
Input 1 Not Operated	(39 Character String)	NONE..	
Input 2 Operated	(39 Character String)	NONE..	
Input 2 Not Operated	(39 Character String)	NONE..	
Input 3 Operated	(39 Character String)	NONE..	
Input 4 Operated	(39 Character String)	NONE..	
Input 5 Operated	(39 Character String)	NONE..	
Input 6 Operated	(39 Character String)	NONE..	
Timer 1 Operated	(39 Character String)	NONE..	
Timer 2 Operated	(39 Character String)	NONE..	
Counter 1 Operated	(39 Character String)	NONE..	
Counter 2 Operated	(39 Character String)	NONE..	
Trip Circuit Fail	(39 Character String)	NONE..	
OC Guard	(39 Character String)	NONE..	
IRIG-B Synch'	(39 Character String)	NONE..	
Hand Reset Outputs	(39 Character String)	NONE..	

OUTPUT OPERATE TIME MENU

Setting	Range	Default	
R1 Min Operate Time	0.1 – 60s	0.1s	
R2 Min Operate Time	0.1 – 60s	0.1s	
R3 Min Operate Time	0.1 – 60s	0.1s	
R4 Min Operate Time	0.1 – 60s	0.1s	
R5 Min Operate Time	0.1 – 60s	0.1s	
R6 Min Operate Time	0.1 – 60s	0.1s	
R7 Min Operate Time	0.1 – 60s	0.1s	
R8 Min Operate Time	0.1 – 60s	0.1s	

R9 Min Operate Time	0.1 – 60s	0.1s	
R10 Min Operate Time	0.1 – 60s	0.1s	
R11 Min Operate Time	0.1 – 60s	0.1s	
R12 Min Operate Time	0.1 – 60s	0.1s	
R13 Min Operate Time	0.1 – 60s	0.1s	
R14 Min Operate Time	0.1 – 60s	0.1s	
R15 Min Operate Time	0.1 – 60s	0.1s	
R16 Min Operate Time	0.1 – 60s	0.1s	
R17 Min Operate Time	0.1 – 60s	0.1s	
R18 Min Operate Time	0.1 – 60s	0.1s	
R19 Min Operate Time	0.1 – 60s	0.1s	
R20 Min Operate Time	0.1 – 60s	0.1s	
R21 Min Operate Time	0.1 – 60s	0.1s	
R22 Min Operate Time	0.1 – 60s	0.1s	
R23 Min Operate Time	0.1 – 60s	0.1s	
R24 Min Operate Time	0.1 – 60s	0.1s	
R25 Min Operate Time	0.1 – 60s	0.1s	
R26 Min Operate Time	0.1 – 60s	0.1s	
R27 Min Operate Time	0.1 – 60s	0.1s	
R28 Min Operate Time	0.1 – 60s	0.1s	
R29 Min Operate Time	0.1 – 60s	0.1s	

LED CONFIG MENU

Setting	Range	Default	
Signal Send 1	(39 Character String)	NONE..	
POR Weak Infeed	(39 Character String)	27....	
DEF POR Weak Infeed	(39 Character String)	27....	
DEF Aided Trip	(39 Character String)	13....	
Signal Send 2	(39 Character String)	NONE..	
DEF Protection	(39 Character String)	11....	
DEF Rev Protection	(39 Character String)	NONE..	
Sig Recvd 2 Flag	(39 Character String)	12....	
UV1 Alarm	(39 Character String)	22....	
UV2 Alarm	(39 Character String)	22....	
UV Trip	(39 Character String)	23....	
SOTF Operated	(39 Character String)	17....	
VTS Alarm	(39 Character String)	18....	
Trip Output	(39 Character String)	NONE..	
Trip Reset	(39 Character String)	NONE..	
Phase A Fault	(39 Character String)	5	
Phase B Fault	(39 Character String)	6	
Phase C Fault	(39 Character String)	7	
Earth Fault	(39 Character String)	8	
Zone 1	(39 Character String)	1	
Zone 2	(39 Character String)	2	
Zone 3	(39 Character String)	3	
Zone 4	(39 Character String)	4	
Aided Trip	(39 Character String)	10....	
Sig Recvd 1 Flag	(39 Character String)	9	
Carrier Guard	(39 Character String)	NONE..	
Power Swing Alarm	(39 Character String)	26....	
Delta Trip Cnt Alarm	(39 Character String)	NONE..	
Total Trip Cnt Alarm	(39 Character String)	NONE..	

High Set	(39 Character String)	19....	
Overvoltage Alarm	(39 Character String)	20....	
Overvoltage	(39 Character String)	21....	
SEF Alarm	(39 Character String)	24....	
SEF Protection	(39 Character String)	25....	
Close Pulse	(39 Character String)	NONE..	
Trip Relay Reset	(39 Character String)	NONE..	
Lockout	(39 Character String)	15....	
A/R Out of Service	(39 Character String)	NONE..	
A/R In Service	(39 Character String)	NONE..	
A/R In Progress	(39 Character String)	14....	
Live Line	(39 Character String)	NONE..	
Live Bus	(39 Character String)	NONE..	
In Sync	(39 Character String)	NONE..	
CB Open	(39 Character String)	16....	
CB Closed	(39 Character String)	NONE..	
CB Failed To Close	(39 Character String)	30....	
System Split	(39 Character String)	32-32.	
Successful Close	(39 Character String)	NONE..	
CB Failed to Open	(39 Character String)	30....	
Check Sync Start	(39 Character String)	NONE..	
Sync In Prog Flag	(39 Character String)	31....	
Close Onto Fault	(39 Character String)	NONE..	
Delta CB Count Alarm	(39 Character String)	30....	
Total CB Count Alarm	(39 Character String)	30....	
CB Not In Ser Alarm	(39 Character String)	NONE..	
CB Memory	(39 Character String)	NONE..	
A/R Not Allowed	(39 Character String)	NONE..	
Input 1 Operated	(39 Character String)	NONE..	
Input 1 Not Operated	(39 Character String)	NONE..	
Input 2 Operated	(39 Character String)	NONE..	
Input 2 Not Operated	(39 Character String)	NONE..	
Input 3 Operated	(39 Character String)	NONE..	
Input 4 Operated	(39 Character String)	NONE..	
Input 5 Operated	(39 Character String)	NONE..	
Input 6 Operated	(39 Character String)	NONE..	
Timer 1 Operated	(39 Character String)	NONE..	
Timer 2 Operated	(39 Character String)	NONE..	
Counter 1 Operated	(39 Character String)	NONE..	
Counter 2 Operated	(39 Character String)	NONE..	
Trip Circuit Fail	(39 Character String)	NONE..	
OC Guard	(39 Character String)	NONE..	
IRIG-B Synch'	(39 Character String)	NONE..	
Self Reset LEDs	(39 Character String)	9,12,14-16, 18,20,22,24,26,29,3 1-32	

CB MAINTENANCE MENU

Setting	Range	Default	
Total CB Trip Count Alarm	OFF, 1 – 9999	OFF	
Delta CB Trip Count Alarm	OFF, 1 – 9999	OFF	
Total CB Close Count Alarm	1-1999	100	
Delta CB Close Count Alarm	1-1999	20	

DATA STORAGE MENU

Setting	Range	Default	
Pre-trigger Storage	10 – 90%	20%	
Record Duration	10 Rec x 1 Sec 5 Rec x 2 Sec 2 Rec x 5 Sec 1 Rec x 10 Sec	10 Rec x 1 Sec	

FAULT LOCATOR MENU

Setting	Range	Default	
Pos Seq Line Impedance	-0.125	10 Ω	
Sec'y Z+ per unit distance	-0.0015	0.5 Ω	
Display distance as	Percent, km, Miles	Percent	
Fault Locator	Disabled, Enabled	ENABLED	

2 Settings Walkthrough

The relay displays are organised into three lists:-

- A list of settings
- A list of meters (instruments)
- A list of fault records

This walkthrough describes the settings and is intended to be read in front of a powered-up relay. The starting point is the relay identifier screen. This is the screen the relay displays when it is first powered-up and can be reached from any display by pressing **CANCEL** a few times.

From this position press the down arrow key once, the relay will display “**SETTINGS MODE**”. From this display the down arrow key can be pressed again to enter the setting list, or the right arrow key ⇒ can be pressed to choose a different list (“**INSTRUMENTS MODE**” or “**FAULT DATA MODE**”). Press the down arrow key ↓. The relay enters the settings list and displays “**SYSTEM CONFIG MENU**”.

In the following section the default values are shown in bold either in the setting range or just after it. Where reference is made to relay inputs or outputs these are shown in italics.

2.1 System Config Menu

This menu contains general settings which allows the relay to be configured. Press ⇒ to open the menu and display the settings.

Active Group (1..8)

There are 8 setting groups in the relay. Some settings can have different values in each group while others have the same value in all groups. This setting controls which group of values is applied to the relay. When it is changed all the settings which can have different values in each group are changed.

Alternate Setting Group (1..8)

It is possible to cause the relay to switch from one setting group to another on application of a signal to the Status Input *Use Alt Setting Grp*. When this status input is energised, the relay will switch from whichever group is currently active to the alternate group defined in this setting. The relay will revert to the previous active setting group when the *Use Alt Setting Grp* Status Input is de-energised.

CT Ratio (0:1..5000:5) **1:2000**

This setting defines the turns ratio of the protection CT. This will allow the meter display to show the correct primary current. This setting does not affect any protection functions.

VT Ratio (1000:90..600000:130) **33000:110**

This setting defines the ratio of the protection VT. This will allow the meter display to show the correct primary voltage. This setting does not affect any protection functions.

CVT in use (NO, YES)

If Capacitive Voltage Transformers are used then this setting should be set to YES. This will give extra security to the protection during the case of severe CVT transients.

Clock Sync from Status (Disabled, Seconds, **Minutes**)

When the Status input defined as Clock Sync is energised, the relay's real time clock will be set to the nearest second or nearest minute according to the setting made here.

View/Edit Group (1..8)

Each setting group can be viewed and edited without making it active. Settings that can be different in each group indicate which group the displayed value belongs to with the letter “G” and the group number in front of the setting description. This setting controls which group is displayed.

IMPORTANT: whichever group of settings are visible may NOT be the settings the relay is using. The relay will only operate on the Active Group regardless of the displayed settings.

Default Screens Timer (Off, 1, 2, 5, 10, 15, 30, **60** mins)

Defines the length of time that the relay will remain on the selected screen before returning to the top of the menu tree. When the relay returns to the default screen, this is indicated by a small inverted D in the top right corner of the LCD screen.

Unless otherwise specified, the default screen is the relay identifier (i.e. the top level of the menu structure).

Backlight Timer (Off, 1, 2, **5**, 10, 15, 30, 60 mins)

Defines the length of time for which the backlight for the LCD screen will remain illuminated after the last keypress.

Date

The current date is set in this menu. The format is DD,MM,YYYY

Time

The current time is set. In this menu only minutes and hours are set. The format is HH,MM the 24 hour clock is used.

Change Password**(NONE)**

The relay is provided with a password feature. If set it will prevent any un-authorized changes to any of the relay settings. The password is a four character word once set it can be disabled by entering the new password "NONE". Once a password has been set, the relay will display a 10 digit code in the Change Password setting. If the password has been lost then an authorised person should contact a Siemens representative, quoting this 10-digit code. This can be used to obtain the current password.

The password must be entered in order to alter any of the relay settings. Once the password has been entered, the relay will remain "logged-in" for 1 hour. After this time, the relay password must be entered again before settings can be changed.

Relay Identifier

The relay is supplied with a default identifier usually the relay type. This can be changed to any 16-digit identifier to give any meaningful identification to the relay. e.g. feeder name or circuit number.

2.2 Distance Protection Menu

The settings for the impedance elements are located in this menu.

Active Scheme

(Time stepped, PUR, POR1, POR2, Reach Extension, Loss Of Load, Acceleration)

There are a number of different protection schemes available in the relay depending upon the model. These can be chosen at this setting. Only one scheme can be active at a time. The schemes are described in Section 3 of this manual.

Carrier Guard**(Disable, Enable)**

This allows the carrier guard feature to be enabled or disabled. Where an output contact is available from the protection signalling equipment, which can indicate that there is a problem with the signalling channel, this can be used to energise a status input defined as *Carrier Guard*.

When enabled, if the status input assigned as *Carrier Guard* is energised, the relay will carry out time delayed trips only – it will not carry out an aided trip under any circumstances, regardless of the condition of the *Signal Received 1* and *Signal Received 2* status inputs.

CT Secondary**(1A, 2A, 5A)**

The relay can operate from 1, 2 or 5 Amp CT secondary circuits. The value MUST be programmed for the correct CT. This will affect the impedance measurements if not programmed correctly.

Line Angle**(0-90° in steps of 5°) 75°**

This is the angle of the positive sequence impedance of the composite transmission line.

EF Comp Z0/Z1 ratio**(0-10) 2.5**

This is the ratio between the magnitudes of the zero sequence and positive sequence impedances of the system. The ratio of Z0/Z1 is used in an internal calculation for earth-fault compensation. This is common for all Zones.

EF Comp Z0 angle**(0-355° in steps of 5°) 75°**

This is the angle of the zero sequence impedance of the system.

Reactive Drop Angle**(-20° .. 20° in steps of 1°) -3°**

Defines the angle at which the reactance line for the Quadrilateral characteristic is inclined to the horizontal. The default setting of -3° is suitable for most applications.

Z1 Extension**(Disable, Enable)**

Operation of the Zone 1 Extension, can be enabled or disabled from this setting. Zone 1 Extension is only active if the *Active Scheme* is set to *Reach Extension*.

Z1 Phase-fault**(Disable, Enable)**

Operation of the Zone 1 phase-fault elements A-B, B-C & C-A, can be enabled or disabled from this setting.

Z1 PF Impedance**(0.1 – 250) 8Ω**

Defines the Zone 1 phase-fault impedance reach in terms of the secondary positive sequence impedance.

Z1X PF Impedance (0.1 – 250) **12Ω**

When the Zone 1 extension scheme is active, this defines the extended Zone 1 phase-fault reach used for the first trip. When the breaker is reclosed, the normal Zone 1 reach is applied for the reclaim time.

If the active scheme is not "Reach Extension", this setting is ignored. See Section 3 of this manual for more detail on relay schemes.

Z1 PF Time Delay (0 – 10000ms)

An independent time delay from 0 – 10s can be applied to the Zone 1 phase-fault protection elements.

Z1 Earth-fault (Disable, **Enable**)

Operation of the Zone 1 earth-fault elements A-E, B-E & C-E, can be enabled or disabled from this setting.

Z1 EF Type (**FWD MHO**, FWD QUAD)

Selects the shape of the Zone 1 element as either Mho or Quad.

Z1 EF Impedance (0.1 – 250) **8Ω**

Defines the Zone 1 earth-fault impedance reach (in terms of secondary positive sequence impedance) for the mho characteristic. If Quad characteristics are used, this setting is ignored.

Z1 EF Resistance (0.1 – 250) **4Ω**

Defines the Zone 1 earth-fault reach along the resistive axis for the quad characteristic. If Mho characteristics are used, this setting is ignored.

NOTE: Residual compensation is not applied to the resistance comparators of the quad characteristics.

Z1X EF Impedance (0.1 – 250) **12Ω**

When the Zone 1 extension scheme is active, this defines the extended Zone 1 earth-fault reach used for the first trip. After the breaker is reclosed, the normal Zone 1 reach is applied during the reclaim time.

If Quad characteristics are used, or the active scheme is not "Reach Extension", this setting is ignored. See Section 3 of this manual for more detail on relay schemes.

Z1X EF Resistance (0.1 – 250) **4Ω**

When the Zone 1 extension scheme is active, this defines the extended Zone 1 earth-fault reach along the resistive axis for the quad characteristic used for the first trip. After the breaker is reclosed, the normal zone 1 reach is applied for the reclaim time.

If Mho characteristics are used, or the active scheme is not "Reach Extension", this setting is ignored. See Section 3 of this manual for more detail on relay schemes.

Z1 EF Time Delay (0 – 10000) **0ms**

An independent time delay from 0 – 10s can be applied to the Zone 1 earth-fault protection elements.

Z2 Phase-fault (Disable, **Enable**)

Operation of the Zone 2 phase-fault elements A-B, B-C & C-A, can be enabled or disabled from this setting.

Z2 PF Impedance (0.1 – 250) **16Ω**

Defines the Zone 2 phase-fault impedance reach in terms of the secondary positive sequence impedance.

Z2 PF Time Delay (0 – 10000) **1000ms**

An independent time delay from 0 – 10s can be applied to the Zone 2 phase-fault protection elements.

Z2 Earth-fault (Disable, **Enable**)

Operation of the Zone 2 earth-fault elements A-E, B-E & C-E, can be enabled or disabled from this setting.

Z2 EF Type (**FWD MHO**, FWD QUAD)

Selects the shape of the Zone 2 element as either Mho or Quad.

Z2 EF Impedance (0.1 – 250) **16Ω**

Defines the Zone 2 earth-fault impedance reach (in terms of secondary positive sequence impedance) for the mho characteristic. If Quad characteristics are used, this setting is ignored.

Z2 EF Resistance (0.1 – 250) **8Ω**

Defines the Zone 2 earth-fault reach along the resistive axis for the quad characteristic. If Mho characteristics are used, this setting is ignored.

NOTE: Residual compensation is not applied to the resistance comparators of the quad characteristics.

Z2 EF Time Delay (0 – 10000) **1000ms**

An independent time delay from 0 – 10s can be applied to the Zone 2 earth-fault protection elements.

Z3 Phase-fault (Disable, **Enable**)

Operation of the Zone 3 phase-fault elements A-B, B-C & C-A, can be enabled or disabled from this setting.

Z3 PF Type (Fwd Mho, Rev Mho, **Offset Mho**)

There are three types of Zone 3 characteristic for phase-faults: Forward (Fwd) Mho, Reverse (Rev) Mho or Offset Mho. If either forward or reverse is selected then these elements become a standard directional element and require a polarising voltage. If an offset characteristic is selected, then operation can occur without polarising voltage.

Z3 PF Impedance (Fwd) (0.1 – 250) **24Ω**

The Zone 3 phase-fault forward impedance reach is defined by this setting, in terms of secondary positive sequence impedance. If the element is selected as a reverse element then this setting is ignored.

Z3 PF Impedance (Rev) (0.1 – 250) **8Ω**

The Zone 3 phase-fault reverse impedance reach is defined by this setting, in terms of secondary positive sequence impedance. If the element is selected as a forward element then this setting is ignored.

Z3 PF Time Delay (0 – 10000) **2000ms**

An independent time delay from 0 – 10s can be applied to the Zone 3 phase-fault protection elements.

Z3 Earth-fault (Disable, **Enable**)

Operation of the Zone 3 earth-fault elements A-E, B-E & C-E can be enabled or disabled from this setting.

Z3 EF Type (Fwd Mho, Rev Mho, **Offset Mho**, Fwd Quad, Rev Quad, Offset Quad).

There are six types of Zone 3 characteristic; Forward (Fwd) Mho, Reverse (Rev) Mho, Offset Mho, Forward (Fwd) Quad, Reverse (Rev) Quad, Offset Quad. If either forward or reverse is selected then these elements become a standard directional element and require a polarising voltage. If an Offset characteristic is selected, then operation can occur without polarising voltage.

Z3 EF Impedance (Fwd) (0.1 – 250) **24Ω**

The Zone 3 earth-fault forward reach impedance values are defined using this setting, in terms of secondary positive sequence impedance. If quad characteristics are used or the element is set as a reverse-looking element, this setting is ignored.

Z3 EF Resistance (Fwd) (0.1 – 250) **12Ω**

Defines the Zone 3 earth-fault forward reach along the resistive axis for the quad characteristic. If Mho characteristics are used or the element is selected as a reverse-looking element, this setting is ignored. NOTE: Residual compensation is not applied to the resistance comparators of the quad characteristics.

Z3 EF Impedance (Rev) (0.1 – 250) **8Ω**

The Zone 3 earth-fault reverse reach impedance values are defined using this setting, in terms of secondary positive sequence impedance. If quad characteristics are used or the element is set as a forward-looking element, this setting is ignored.

Z3 EF Resistance (Rev) (0.1 – 250) **4Ω**

Defines the Zone 3 earth-fault reverse reach along the resistive axis for the quad characteristic. If Mho characteristics are used or the element is set as a forward-looking element, this setting is ignored. NOTE: Residual compensation is not applied to the resistance comparators of the quad characteristics.

Z3 EF Time Delay (0 – 10000) **2000ms**

An independent time delay from 0 – 10s can be applied to the Zone 3 earth-fault protection elements.

Z4 Phase-fault (Disable, Enable)

The reverse Zone 4 phase-fault elements A-B, B-C & C-A, can be enabled or disabled from this setting. Zone 4 is used for Blocking Schemes and does not cause the Trip output to be raised.

Z4 PF Impedance (0.1 – 250) **16Ω**

Defines the Zone 4 phase-fault impedance reach (in terms of secondary positive sequence impedance) for the mho characteristic.

Z4 PF Time Delay (0 – 10000) **0ms**

An independent time delay from 0 – 10s can be applied to the Zone 4 phase-fault protection elements.

Z4 Earth-fault (Disabled, Enabled)

Operation of the Zone 4 earth-fault elements A-E, B-E & C-E, can be disabled from this setting. Zone 4 is used for Blocking Schemes and does not cause the Trip output to be raised.

Z4 EF Impedance (0.1 – 250) **16Ω**

Defines the Zone 4 earth-fault impedance reach (in terms of secondary positive sequence impedance) for the mho characteristic. If Quad characteristics are used, this setting is ignored.

Z4 EF Resistance (0.1 – 250) **16Ω**

Defines the Zone 4 earth-fault reach along the resistive axis for the quad characteristic. If Mho characteristics are used, this setting is ignored.

NOTE: Residual compensation is not applied to the resistance comparators of the quad characteristics.

Z4 EF Time Delay (0 – 10000) **0ms**

An independent time delay from 0 – 10s can be applied to the Zone 4 earth-fault protection elements.

POR Weak Infeed Tripping (Disabled, Enabled)

Allows the weak infeed tripping features to be turned on or off, where the Permissive overreach scheme is being applied. See Section 3 of this manual for a full description of the Weak Infeed tripping feature.

WI Voltage Level(5-85) 54v

Specifies the phase-neutral voltage below which a Weak Infeed fault can be assumed. See Section 3 of this manual for a full description of the Weak Infeed tripping feature

POR Current Rev Reset (0 – 60000) **200ms**

When there is a change indirection of the flow of current (due to circuit breakers opening), the relay will restrain for this time delay to prevent race conditions between the drop-off of the remote end signal send and the drop off of the local measuring element. Used only with Permissive Overreach schemes. See Section 3 of this manual for a full description of the Current Reversal Guard feature.

POR CB Echo Pulse (0 – 60000) **250ms**

This is the length of pulse “Echoed” back to the remote end when a signal is received from the remote end distance protection and the local breaker is open. Used only with POR scheme. See Section 3 of this manual for a full description of the CB Echo Pulse feature.

LOL Level (0.1 – 0.9) **0.5 x I_N**

Where the Loss of Load scheme is used, a LOL condition occurs if the current level in one or two phases drops below this level, but the current in the remaining phase(s) is above this level. When this occurs, the relay will remove the time delay from Zone 2 for the *LOL Time Limit* (see below). Thus, the relay will allow tripping for 100% of the line upon detection of a loss of load (i.e. a fault outside of the local zone 1 for which the remote end breaker has tripped). See Section 3 of this manual for a full description of the Loss of Load feature.

LOL CB Op Delay (0 – 60000) **20ms**

This delay allows for pole scatter between phases. A short delay is placed on the operation of the LOL detector to allow for slight differences in the opening time between poles of the circuit breaker, thus preventing nuisance alarms. The standard value of 20ms will be suitable for most cases.

LOL Time Limit (0 – 60000) **40ms**

Maximum time after the loss of load condition is detected for which the Zone 2 time delay will be removed. The standard value of 40ms will be suitable for most applications.

Power Swing Detector (Disable, Enable)

This setting allows the Power Swing detector to be enabled or disabled.

PSD Zone Blocking (Zone 1, **Zone 2, Zone 3, Zone 4**)

This defines which Zones of protection tripping would be blocked for in the event of a Power Swing.

PSD Shape (Circular, Rectangular)

Allows setting of the Power Swing Zone characteristics as either circular or rectangular.

PSD Blinders (Disable, Enable)

This allows blinders to be applied to the Power Swing Zone to prevent load encroachment. These are applied parallel to the line angle when enabled.

PSD Inner Fwd Impedance (0.1 – 250) **24Ω**

Sets the inner impedance reach in the forward direction (on the line angle) for the PSD characteristic. This is usually set equal to, or greater than, the Zone 3 reach.

PSD Inner Rev Impedance (0.1 – 250) **8Ω**

Sets the inner impedance reach in the reverse direction (on the line angle) for the PSD characteristic. This is usually set equal to, or greater than, the Zone 3 reverse reach.

PSD Inner FWD Blinder (0.1 – 250) **16Ω**

This is the impedance (perpendicular to the line angle) between the line impedance and the blinder applied to the PSD Zone, to the right of the line characteristic. The blinder is applied parallel to the line angle.

PSD Inner REV Blinder (0.1 – 250) **16Ω**

This is the impedance (perpendicular to the line angle) between the line impedance and the blinder applied to the PSD Zone, to the left of the characteristic. The blinder is applied parallel to the line angle.

PSD Outer Multiplier (1.05 – 2) **1.5 x**

The outer reach of the Power Swing detector is set as a multiple of the inner reach, normally 1.5 times the inner reach.

PSD Transit Time (0 – 1000) **50ms**

This is the length of time for which the impedance characteristic must be between the inner and outer Zones of the Power Swing Detector for a Power Swing to be detected. The default setting of 50ms should be suitable for most applications.

2.3 Aux Protection Menu

Any additional protection elements are programmed in this section.

High Set (Disabled, Enabled)

Overcurrent high set elements can be enabled or disabled using this setting.

HS Level (0.1 – 35) **4 x I_N**

The overcurrent setting is applied here. It is set in multiples of the nominal current, I_N which is set in the DISTANCE PROTECTION MENU under the *CT Secondary* setting.

HS Time Delay (0.00 – 60s) **1.00s**

A definite time delay from 0 – 1s can be added to the instantaneous operating time of the high set elements.

SEF Protection (Disabled, Enabled)

The Sensitive Earth-fault Protection can be enabled or disabled using this setting.

SEF Current Setting (0.02 – 0.95) **0.10 x I_N**

The level of residual current at which the Sensitive Earth-fault Element will operate. The SEF element has two sequential time delays, one of which can be used to give an alarm, the other a trip. The *SEF TRIP* delay timer is only started after operation of the SEF Alarm.

SEF Alarm Delay (0.00 – 60s) **1.00s**

Time delay after which the *SEF Alarm* output will operate, if the residual current remains above the SEF Current Setting.

SEF Trip Delay (0.00 – 60s) **1.00s**

After the operation of the *SEF Alarm*, if the residual current remains above the SEF Current Setting for this delay, the relay will trip, and operate the *SEF Trip* output.

Overvoltage Prot (Enabled, Disabled)

The Overvoltage elements can be enabled or disabled using this setting.

OV Alarm Level (1.00 – 1.50xV_N) **1.07 x V_N**

The level of Overvoltage at which the *OV Alarm* timer will start.

OV Alarm Time Delay (0 – 1000ms)

Time delay after which the *OV Alarm* output will operate, if the system voltage on any phase remains above the OV alarm level.

OV Trip Level (1.00 – 1.50xV_N) **1.15 x V_N**

The level of Overvoltage at which the *OV Trip* timer will start.

OV Trip Time Delay (0, 1, ... 1000ms)

Time delay after which the *OV Trip* output will operate, if the system voltage on any phase remains above the OV trip level.

Undervoltage Prot. (Enabled, Disabled)

The Undervoltage elements can be enabled or disabled using this setting.

UV Block Level (Disabled, 1 – 60.0 V) **3.0 V**

If the system voltage drops below this level, the Undervoltage elements will be blocked. This may be used to prevent nuisance alarms when the system is dead.

UV1 Level (5.0 – 80.0 V) **55.0 V**

This sets the pick-up level of the first Undervoltage element. This may be used as either the alarm or the trip output.

UV1 Time Delay (0.00 – 60s) **1.00s**

Time delay after which the *UV1* output will operate, if the voltage remains below the *UV1* trip level.

UV1 Hysteresis (1, 2, ..., 90 %),

Percentage difference between pick-up and drop off of the *UV1* element.

UV1 O/P Phases (**Any 1**, All)

Determines whether the *UV1* element will operate for Undervoltage on all three phases or any one phase.

UV1 Tripping (Enabled, **Disabled**)

Determines whether operation of the *UV1* element will cause the relay's *Trip Output* to operate.

UV2 Level (5.0 – 80.0 V) **55.0 V**

This sets the pick-up level of the *UV2* element. This may be used as either the alarm or the trip output.

UV2 Time Delay (0.00 – 60s) **10.00s**

Time delay after which the *UV2* output will operate, if the voltage remains below the *UV2* trip level.

UV2 Hysteresis (1 – 90%) **2 %**

Percentage difference between pick-up and drop off of the *UV2* element.

UV2 O/P Phases (**Any 1**, All)

Determines whether the *UV2* element will operate for Undervoltage on all three phases or any one phase.

UV2 Tripping (Enabled, **Disabled**)

Determines whether operation of the *UV2* element will cause the relay's *Trip Output* to operate.

SOTF (Enabled, **Disabled**)

This setting determines whether the Switch On To Fault protection is enabled or not.

SOTF Mode (**AC SOTF**, DC SOTF)

The Switch On To Fault feature has two modes of operation. It can be energised from an AC function or a DC function. The DC SOTF function is energised by the operation of a status input from the CB manual close handle (i.e. a D.C. signal). The AC SOTF function monitors the line current and voltage (i.e. the AC signals) and thus cannot be used if the VT is on the busbar side of the relay.

SOTF O/C Operate Level (0.3 – 4 x I_N)

This current setting is used as a minimum value to cause operation of the SOTF function after 25ms of fault current on all three phases.

AC SOTF Pickup Delay (0-60000ms) **10000ms**

The AC line check time delay which is used to reset the function has a nominal setting of 10s this can be adjusted from 0 – 60s.

Min AUX DC SOTF Dead Time (0-60000ms) **10000ms**

The minimum DC line check time delay for use with CB auxiliary contacts which is used to reset the function has a nominal setting of 10s this can be adjusted from 0 – 60s.

VT Supervision (Enabled, **Disabled**)

This checks for the security of the VT circuit. It can be enabled or disabled.

VTS Latched Operation (Enabled, Disabled)

If residual/NPS current is detected above the VTS Ires level, the VTS protection blocking will reset unless this setting is enabled. If Enabled the current will only reset the VTS if it is detected before the VTS Latch Op. Delay expires.

VTS Mode (**Alarm Only**, Alarm & Inhibit)

If the VTS operates it can be selected to give an alarm only or it can inhibit the operation of the impedance elements.

VTS Phase-fault Inhibit (Enabled, **Disabled**)

During a fault condition the VTS is reset when the zero sequence current exceeds the setting. For a phase-fault there is no zero sequence current therefore the relay may be inhibited during a phase-fault.

With this setting disabled, the relay will trip for a two-phase VT failure.

With this setting enabled, the relay will remain stable for a two-phase VT failure but will not trip if a phase-fault occurs during such a failure.

VTS Input Source (Res.I/V, NPS I/V)

This selects to use either Residual voltage and current or Negative Phase Sequence voltage and current to detect VT failure.

VTS Ires Level (0.05 – 4 x I_N) **0.3 x I_N**

VTS Vop Level (1 – 100V) **20V**

The VTS feature operates by measuring the summated (residual) or Negative Phase Sequence voltages of the healthy system, and comparing this with the measured residual or Negative Phase Sequence current. The VTS will operate if the relay detects the relevant voltage without detecting a corresponding sequence current.

These settings define the levels of current and voltage used. They are set in the form of residual quantities which is equal to 3x the Zero Sequence level therefore the setting should be set to 3x the actual Negative Phase Sequence level required when NPS is selected.

The default residual voltage setting of 20 volts is suitable for most applications, but this can be changed to make the function more or less sensitive. The current setting is made in terms of the nominal current, and the default setting is 30%. The default settings used here are suitable for most applications.

A 1P earth fault will have equal levels of ZPS and NPS current and voltage. A pure P-P fault will contain significant levels of NPS V&I but no ZPS/Residual V&I.

VTS Alarm PU Delay (0 – 60000ms) **100ms**

This is the minimum time for which the VT fail conditions must remain on the system before the VT alarm is operated. It is usually set to 100ms to avoid nuisance alarms.

VTS Latch PU Delay (0 – 60000ms) **5000ms**

When latch is enabled this setting selects the duration after a VTS is detected within which the VTS will reset for an current increase above the VTS Ires Level.

OC Guard (Enabled, Disabled)

Enables or disables the overall operation of the Overcurrent Guard function which can be used to set the minimum current level for which a Distance element operation can occur.

OC Guard Setting (0.01-25 xI_n) **1.5xI_n**

Sets the current level as a multiple of rated current which must be exceeded for a Distance protection operation to occur.

OC Guard Delay (0-864000s) **1s**

Sets the delay for which current must exceed the OC Guard level before a Distance protection can occur.

OC Guard Z1 (OCG Z1 Enabled, **OCG Z1 Disabled**)

OC Guard Z2 (OCG Z2 Enabled, **OCG Z2 Disabled**)

OC Guard Z3 (OCG Z3 Enabled, **OCG Z3 Disabled**)

OC Guard Z4 (OCG Z4 Enabled, **OCG Z4 Disabled**)

The zones upon which the OC Guard block is applied are individually selected using these settings. When Disabled the zone will operate for an impedance inside it regardless of the current level.

Fwd DEF Protection (Enabled, Disabled)

Enables or disables the operation of the forward – looking DEF element.

DEF Active Scheme (DEF POR, DEF BOR, DEF Direct Trip)

The DEF protection can be applied either as a direct tripping time graded element or using a signalling channel in either a permissive scheme or a blocking scheme, with time graded operation as a back-up.

Fwd DEF Char Angle (-15, -10, ... 95°) **-45 deg**

This is the angle between the residual current and the residual voltage for the forward-looking DEF element. The residual voltage is taken as the reference, so for an inductive circuit the angle will be negative.

Fwd DEF Setting (0.05, 0.10, ... 4.00 xI_n) **1.00 xI_n**

This setting defines the current Multiplier Setting for the forward-looking DEF element if set as an IDMTL characteristic, or the pickup level if set as a DTL.

Fwd DEF Char (IEC-NI, IEC-VI, IEC-EI, IEC-LTI, ANSI-MI, ANSI-VI, ANSI-EI, DTL)

Defines the operating characteristics of the relay.

Fwd DEF Time Mult (IEC/ANSI) (0.025, 0.050, ..., 1.600) **1.000**
 Defines the time multiplier setting applied to the IDMTL characteristics.

Fwd DEF Delay (DTL) (INST, 0.01, 0.02, ..., 20.00s) **5.00 s**
 If the forward-looking DEF element uses the DTL Overcurrent characteristic, this defines the time delay.

Fwd DEF Reset ((ANSI) DECAIVING, INST, 1, 2, ..., 60s) **INST s**
 This setting defines the reset characteristics for the forward-looking DEF Element. May be set as Instantaneous, decaying or as a DTL.

Rev DEF Protection (**Enabled**, Disabled)
 Enables or disables the operation of the reverse-looking DEF element.

Rev DEF Char Angle (-15, -10, ... 95°) **-45 deg**
 This is the angle between the residual current and the residual voltage for the reverse-looking DEF element. The residual voltage is taken as the reference, so for an inductive circuit the angle will be negative.

Rev DEF Setting (0.05, 0.10, ... 4.00 xIn) **1.00 xIn**
 This setting defines the current Multiplier Setting for the forward-looking DEF element if set as an IDMTL characteristic.

Rev DEF Char (**IEC-NI**, IEC-VI, IEC-EI, IEC-LTI, ANSI-MI, ANSI-VI, ANSI-EI, DTL)
 Defines the operating characteristics of the relay.

Rev DEF Time Mult (IEC/ANSI) (0.025, 0.050, ..., 1.600) **1.000**
 Defines the time multiplier setting applied to the IDMTL characteristics.

Rev DEF Delay (DTL) (INST, 0.01, 0.02, ..., 20.00s) **5.00 s**
 If the forward-looking DEF element uses the DTL Overcurrent characteristic, this defines the time delay.

Rev DEF Reset ((ANSI) DECAIVING, INST, 1, 2, ..., 60s) **INST**
 This setting defines the reset characteristics for the forward-looking DEF Element. May be set as Instantaneous, decaying or as a DTL.

DEF WI Res OV Setting (0, 1, ..., 20V)
 Determines a minimum level of residual voltage, which must be present on the system for the relay to carry out a Weak Infeed trip when using the DEF POR scheme. See Section 12 of this manual for more detail on DEF Schemes.

DEF Current Rev Reset (0-60000) **200 ms**
 A delay imposed on the DEF protection in the case of a current reversal. This will give the remote end signal send a chance to drop-off, and prevent mal-trips due to race condition on parallel feeders. See Section 12 of this manual for more detail on DEF Schemes.

CB Echo Pulse Width (0-60000) **250ms**
 If a DEF signal is received from the remote end and the local breaker is open, the relay will close it's Signal Send 2 output. In conjunction with the DEF at the remote end, this will cause the remote end breaker to trip. The length if the signal "echoed" back to the other end is defined here. See Section 12 of this manual for more detail on DEF Schemes.

Trip Circuit Fail (**Disabled**, Enabled)
 Allows the trip circuit to be monitored by a status input. If this status input is de-energised it will indicate that the Trip Circuit is faulty and operate the *Trip Circuit Fail* relay output.

2.4 Auto Reclose Menu

A/R In Service (**In**, Out)
 This setting allows the AR to be switched in and out of service directly. The autorecloser can also be switched in and out of service using a pair of Status Inputs (*AR In*, *AR Out*).

Dead Bar Charge (Enabled, **Disabled**)
 Allows a close pulse to be issued to the breaker if the Busbar voltage is less than the Bus Dead voltage level and the Line voltage is greater than the Line Live voltage level during an Autoreclose sequence.

Dead Line Charge (Enabled, **Disabled**)
 Allows a close pulse to be issued to the breaker if the Line voltage is less than the Line Dead voltage level and the Bus voltage is greater than the Bus Live voltage level during an Autoreclose sequence.

Dead Line & Dead Bar Close (Enabled, **Disabled**)

Allows a close pulse to be issued to the breaker if both the Line and Busbar voltages are less than the Dead voltage levels.

Check Sync Close (Enabled, **Disabled**)

Allows a close pulse to be issued to the breaker if both the Line and Busbar voltages are greater than the Live voltage levels during an Autoreclose sequence if synchronising conditions between the Line and Busbar voltages are also met.

Unconditional Close (**Enabled**, Disabled)

Allows closing of the breaker under any system conditions during an Autoreclose sequence.

Manual Close DBC (Enabled, **Disabled**)

Checks that the Busbar voltage is less than the Bus Dead voltage level before a close pulse is issued to the breaker following a Manual Close request.

Manual Close DLC (Enabled, **Disabled**)

Checks that the Line voltage is less than the Line Dead voltage level before a close pulse is issued to the breaker following a Manual Close request.

Manual Close DLDB (Enabled, **Disabled**)

Checks that both the Line and Busbar voltages are less than the Dead voltage levels before a close pulse is issued to the breaker following a Manual Close request.

Manual Close CS (Enabled, **Disabled**)

Checks synchronism between the Line and Busbar voltages, before a close pulse is issued to the breaker following a Manual Close request.

Deadtime (0 – 900s) **15s**

The Deadtime is started when the trip initiation drops off and the circuit breaker has opened. This delay allows the fault conditions on the system to decay before a close pulse is issued to the breaker.

Live Line Check (Enabled, **Disabled**)

If the Line voltage is “dead” for 2 seconds before the trip, a maintenance condition is assumed and no ARC is attempted. Where VTs are mounted on the busbar side of the circuit breaker this feature should be disabled. This function also initiates an additional check that the line is dead before the Deadtime will start.

Check Sync During Deadtime (Enabled, **Disabled**)

With this setting disabled the relay will wait until the end of the deadtime before it checks the synchronism of the line and bus voltages. With it enabled, if the line and bus voltages come into synchronism during the deadtime a close pulse will be issued to the breaker.

VT Fail Lockout (Enabled, **Disabled**)

If the CB is closed and either Line or Bus is considered Live whilst the other is considered dead, this indicates that there is a VT Fail (blown fuse) on the “dead” side. This condition will drive the Autoreclose to Lockout if this setting is set to Enabled.

CB Close Pulse (0.2..20) **2s**

This is the length of the close pulse. If the circuit breaker has not closed within this time, the relay will operate the *CB fail to Close* output and the autorecloser will lockout.

Reclaim Time (OFF..600) **20s**

This is the time after the close pulse has been issued before the Autoreclose cycle resets itself. If a fault occurs during the reclaim time, the relay will lockout the autorecloser.

Dead Line Charge Delay (0 – 60) **0s****Dead Bar Charge Delay** (0 – 60) **0s**

These settings allow different Deadtimes to be used for DBC and DLC. These times are in addition to the standard Deadtime setting.

Reclose Blocked Delay

If the status input assigned to *Block Autoreclose* remains energised for longer than this time delay the relay will lockout the autorecloser.

Sync Close Delay (0 – 60) **1s**

This is the maximum length of time allowed between the end of the *Deadtime* and the line and bus voltages coming into synchronism. If synchronism is not achieved within this time, the relay will lockout.

Sequence Fail Timer (Off – 600)

This setting defines the maximum time that the relay will wait for the Trip conditions to be cleared – trip reset, breaker open and that the line is dead if Live Line Check is enabled – before it locks out the autorecloser.

CB Fail To Open Delay (50 – 2000) **200ms**

Once a trip signal has been issued, if the breaker fails to open before the Open Delay has elapsed the *CB Fail to Open* alarm will be given.

Reset LO By Timer (Enabled, **Disabled**)

Normally, the AR lockout will be reset automatically when the Breaker is successfully re-closed. Alternatively, it is possible to reset the Lockout after a time delay.

Minimum LO Timer (0 – 60) **2s**

If the *Reset LO by Timer* setting is enabled, the lockout will reset after this time delay.

Z2 AR Start (Enabled, **Disabled**)**Z3 AR Start** (Enabled, **Disabled**)**DEF AR Start** (Enabled, **Disabled**)**DEF AIDED AR Start** (Enabled, **Disabled**)

These settings individually select which protection elements cause an autoreclose sequence to start or lockout.

Fault Type AR Start (**2P/1P**, All)

This selects which type of fault will start an autoreclose. If *2P/1P* is selected, a 3-Phase fault will cause the autorecloser to lockout.

2.5 Sync Menu

Sync Connection (**Phase B-Earth** / Phase A-Phase B)

This defines the connection of the busbar VT used to provide the sync voltage.

Check Sync Vnom (**63.5v**, 110v)

This specifies the nominal voltage upon which the voltage percentage settings are based.. This should be set to 63.5v on Ohmega relays.

Bus: Dead | Live (5:10..150:155) **20|90%**

These settings define the “live” and “dead” conditions of the Busbar voltage. Once the voltage goes below the “dead” level, the relay will treat the line as dead, until the voltage rises above the “live” level. Similarly when the voltage goes above the live level, the relay will treat the line as live until it goes below the “dead” level.

Line: Dead | Live (5:10..150:155) **20|90%**

These settings define the “live” and “dead” conditions of the Line voltage. Once the voltage goes below the “dead” level, the relay will treat the line as dead, until the voltage rises above the “live” level. Similarly when the voltage goes above the live level, the relay will treat the line as live until it goes below the “dead” level.

Bus Undervolts (OFF, 150) **90%**

This sets the maximum allowable undervoltage on the bus for a check sync close.

Line Undervolts (OFF, 150) **90%**

This sets the maximum allowable undervoltage on the line for a check sync close.

Voltage Differential (OFF, 100) **10%**

This is the maximum allowable difference in magnitude between the line voltage and the busbar voltage for a check sync close.

Split Angle (OFF, **175Deg**)

This is the angle at which the relay will switch from check sync mode to system sync mode.

MC Split Action (**System Sync**, Check Sync)

This is the action that will be carried out, if a manual close is attempted, when a system split condition is detected

ARC Split Action (System Sync, **Lockout**)

This defines the relay operation when the angle between line and bus voltage reaches the Split angle during an auto-reclose operation.

Check Sync Angle (5 – 90) **20 deg**

These are the conditions that must exist for the relay to indicate that the voltages are In Sync, during a **Check Sync** operation. These conditions must exist for longer than the Check Sync Timer setting.

Check Sync Slip (OFF..2000) **50 mHz**

This is the maximum frequency difference between the bus and line voltages.

Check Sync Timer (OFF – 100)

This is the minimum time that the bus and line voltage signals must remain in synchronism before a close pulse is issued. Older auto-reclose systems used this time to ensure that the slip frequency between voltages was below a chosen level. Normally it will be set to off, and the maximum slip frequency can be set as the check sync slip set. However, if the auto-reclose system is being used in conjunction with older recloser systems (e.g. the Reyrolle GAD), this setting is included to ensure that equivalent settings can be made on the relay.

System Sync Angle (5..90) **10 deg**

These are the conditions that must exist for the relay to indicate that the voltages are In Sync, during a System Sync operation. Also the angle between the two signals must be decreasing. The conditions are more onerous than for a check sync condition.

System Sync Slip (OFF..2000) **125mHz**

This defines the maximum slip frequency for a System Sync closure to occur.

System Sync Timer (OFF..100)

This is the minimum time that the bus and line voltage signals must remain in synchronism before a close pulse is issued.

2.6 Reylogic Config Menu

Elements of functions that have had the logic configured in REYLOGIC are found in this menu.

SR Dropoff (0..60000) **1ms**

The Distance signal received can be extended using this timer to provide a variable pulse length.

SS Dropoff (0..60000) **1ms**

The Distance send signal can be delayed using this timer to provide a variable pulse length.

Permissive Trip Time Delay (0..60000) **20ms**

This is used for the distance blocked overreach scheme (BOR). This is the time for which the relay will wait for a blocking signal from the remote end before a carrier-aided trip is carried out.

SR2 Dropoff (0..60000) **1ms**

The DEF signal received can be extended using this timer to provide a variable pulse length.

SS2 Dropoff (0..60000) **1ms**

The DEF signal send can be delayed using this timer to provide a variable pulse length.

DEF Perm Trip Time (0..60000) **20ms**

This is used for the DEF BOR scheme. This time delay is used to delay the signal from the remote end before it is gated with the local DEF element. In other words, this is the time delay that the relay will wait for a blocking signal from the remote end before a carrier-aided trip is carried out.

Timer 1 Pickup Delay (0..60000) **1ms**

This is a time for which the Status Input *Timer 1* must be energised before the *Timer 1 Operated* output is operated.

Timer 1 Dropoff Delay (0..60000) **0ms**

This is a time for which the *Timer 1 Operated* output remains operated, once the Status Input *Timer 1* has been de-energised.

Timer 2 Pickup Delay (0..60000) **1ms**

This is a time for which the Status Input *Timer 2* must be energised before the *Timer 2 Operated* output is operated.

Timer 2 Dropoff Delay (0..60000) **0ms**

This is a time for which the Status Input *Timer 2* must be energised before the *Timer 2 Operated* output is operated.

Counter 1 Target (1..60000) **1**

This is the number of pulses which must be applied to the Status Input *Counter 1* before the *Counter 1 Operated* output is operated.

Counter 2 Target (1..60000) 1

This is the number of pulses which must be applied to the Status Input *Counter 2* before the *Counter 2 Operated* output is operated.

2.7 Status Config Menu

The number of status inputs can vary with the relay model type. Each of the status inputs can be mapped to any one or more of the relay functions. The following list shows the purpose of the function.

Signal Receive 1

This is the received signal from the remote end of a distance protection scheme.

Carrier Guard

Energisation of this status input will revert the distance protection to a time stepped distance scheme. Can be used if the signalling channel fails. As soon as this status input is de-energised, the relay will revert to the Active Scheme.

Unstabilise Relay

This input is used in the Blocked Overreach (BOR) scheme to force the signal send logic of the scheme into the state required to allow the remote relay to perform an aided trip when a fault is applied.

Block Mode Inhibit

This input is used in conjunction with the distance protection Blocking Scheme. When active, this signal prevents aided tripping caused by the removal of the block signal by the remote relay.

Block Reach Extension

When the reach extension scheme is enabled and this status input is energised, the relay will use the normal zone 1 reach instead of the extended reach for the first trip of an auto-reclose sequence.

Signal Receive 2

This is status input used to receive the signal from the remote end of a DEF protection scheme.

Block DEF

Energisation of this status input will prevent all DEF operations (both aided and backup trips).

DEF Block Mode Inhibit

When this Status Input is energised the relay will not carry out an aided trip. The back-up trip function will still operate.

DC SOTF Manual Close

This status input must be used if the *Switch On To Fault mode* is set to *DC SOTF* started by a contact from the circuit breaker closing handle. It is disabled by default. For 400ms after this element is first energised, the relay will remove the time delay from Zone 3. See Section 2 of this manual for a full description of the *Switch On To Fault* feature.

Start Aux DC SOTF

This status input must be used if the *Switch On To Fault mode* is set to *DC SOTF* started from a CB auxiliary contact. If the aux contact has indicated that the CB has been open for greater than the Min AUX DC SOTF Dead Time, SOTF will allow fast fault clearance for 400ms by the removal of the time delay from Zone 3. See Section 2 of this manual for a full description of the *Switch On To Fault* feature.

VT Circuits Isolated

This input is used to detect a three-phase VT failure, and should be connected to an auxiliary contact from a three-phase MCB. The relay will indicate a VTS condition whenever this status input is energised.

Trigger Storage

An external device can be used to trigger the waveform storage whenever this status input is energised.

Increment Trip Count.

The relay records the number of trip operations carried out. If the circuit breaker is tripped by another protection device, this status input can be used to increment the trip counter. This means that the relay will record the total number of trips carried out by the breaker, regardless of which device carried out the tripping. One example of the use of this would be for a single switch substation where two distance relays control the same circuit breaker. By connecting the trip contact of one relay to this status input on the other relay (and vice versa) the trip counter on each relay will record the total number of trips for that breaker.

Reset Total Trip Cnt

Energising this Status Input will reset the Total trip count. The number of trips recorded by the Total Trip Counter carried out by the relay can be viewed in the INSTRUMENTS mode of the relay.

Reset Delta Trip Cnt

Energising this Status Input will reset the Delta trip count. The number of trips recorded by the Delta Trip Counter carried out by the relay can be viewed in the INSTRUMENTS mode of the relay.

Reset Total CB Close

Energising this Status Input will reset the Total CB close counter. The number of trips recorded by the Total CB Close Counter carried out by the relay can be viewed in the INSTRUMENTS mode of the relay.

Reset Delta CB Close

Energising this Status Input will reset the Total CB close count. The number of trips recorded by the Delta Trip Counter carried out by the relay can be viewed in the INSTRUMENTS mode of the relay.

Use Alt Settings Grp

This input when energised will cause the relay to switch to the alternative setting group defined in the system configuration menu. The relay will revert to the original setting group when this status input is de-energised.

Block Reclose

Energising this status input will cause a temporary auto-reclose inhibit. This will pause the autorecloser at whatever point it is at. All timers will stop until this Status Input is de-energised. If this status input is energised for longer than the *Reclose Blocked Delay*, the relay will lockout.

A/R Out

A/R In These switch the autorecloser In and Out. A pulse to the “AR in” status input will switch it into service, one to the “AR out” will switch it out of service. If both are high simultaneously, the autorecloser will be switched out of service.

Go Direct To Lockout

Energising this status input will cause the autorecloser to go immediately to lockout. While this input is kept high, the autorecloser will not leave lockout even if an attempt is made to reset it.

Trip And Reclose

Energising this status input will cause the relay to trip and initiate an autoreclose. All conditions for autoreclosing must still be met. This is designed as a test function.

External A/R Start

Energising this status input will cause the relay to start an autoreclose sequence. All conditions for autoreclosing must still be met. This is used where an external device has caused the trip but this relay is required to control the autoreclose sequence.

Reset Lockout

Energising this status input will reset the relay from a lockout condition. This is not normally required because the lockout condition will be reset when the breaker is successfully reclosed.

Sync Override

When this status input is energised during an Autoreclose sequence, the synchroniser is overridden and a close pulse is issued to the breaker regardless of the synchronising conditions. All other Autoreclose conditions must still be met. This would be used where an external Synchronising device is in use.

Manual Sync Override

When this status input is energised during a Manual Close sequence, the synchroniser is overridden and a close pulse is issued to the breaker regardless of the synchronising conditions. All other manual close conditions must still be met. This would be used where a manual Synchronising override panel switch is applied for manual closing.

CB Phase A Closed

This status input should be energised to indicate that Phase A of the Circuit Breaker is closed.

CB Phase B Closed

This status input should be energised to indicate that Phase B of the Circuit Breaker is closed.

CB Phase C Closed

This status input should be energised to indicate that Phase C of the Circuit Breaker is closed.

CB Phase A Open

This status input should be energised to indicate that Phase A of the Circuit Breaker is open.

CB Phase B Open

This status input should be energised to indicate that Phase B of the Circuit Breaker is open.

CB Phase C Open

This status input should be energised to indicate that Phase C of the Circuit Breaker is open.

Manual Close

This input will cause a Manual Closing sequence to commence.

Input 1 ... 4

In order to utilise the status inputs and output relay matrix a number of connections have been created. These are named as Input 1..n where n is a maximum of 4. This will depend upon the relay model type.

Input 5a, 5b, 5c, 5d

When all four of these status inputs are energised the relay will operate the *Input 5 Operated* relay output. This acts as a four input AND gate. By assigning more than one of these labels to the same relay input, a 3 or a 2 input AND gate can be created.

Input 6a, 6b, 6c, 6d

When all four of these status inputs are energised the relay will operate the *Input 5 Operated* relay output. This acts as a four input AND gate. By assigning more than one of these labels to the same relay input, a 3 or a 2 input AND gate can be created.

Timer 1

When this is energised, timer 1 will start. If the Status Input remains energised for longer than the *Timer 1 pick-up delay* (see Reylogic Config) this will operate the *Timer 1 Operated* Output. When de-energised the output will drop-off after the *Timer 1 Drop Off Delay*. If the timer is de-energised before the *Timer 1 pick-up delay* it will reset to zero.

Timer 2

As above.

Counter 1 Count

Energising this SI will increment Counter 1 by 1. When the counter reaches the target set as *Counter 1 Target* (Reylogic Configuration) the output assigned to *Counter 1 Operated* will operate.

Counter 1 Reset

Energising this will reset *Counter 1* to Zero.

Counter 2 Count

Energising this SI will increment Counter 2 by 1. When the counter reaches the target set as *Counter 2 Target* (Reylogic Configuration) the output assigned to *Counter 2 Operated* will operate.

Counter 2 Reset

Energising this will reset *Counter 2* to Zero.

Trip Circuit Fail

This input is used to monitor the trip circuit for open circuit

Clock Sync

Energising this Status Input will cause the relay to reset to either the nearest minute or nearest second depending on the setting made in the System Config menu.

2.8 Output Config Menu

Depending upon the configuration of the relay there are a large number of signals which can be mapped to output contacts.

Protection Healthy

This output monitors the condition of the relay and dc power supply to the relay. This is usually mapped to one of the changeover outputs, and connected to the normally closed contact (by default relay 1). When this function is selected it will permanently operate the selected relay. By using a normally closed contact if there is any failure then this contact will close giving a fail-safe alarm condition.

Signal Send 1

Depending on the active scheme for Distance Protection, this output is used for Distance Protection Signalling. See Section 3 of this manual for a full description of this feature.

POR Weak Infeed

Indicates that the Weak Infeed logic for the distance protection POR scheme has operated.

DEF POR Weak Infeed

Indicates that the Weak Infeed logic for the DEF scheme has operated.

DEF Aided Trip

Operates when the operation of the DEF element has been “aided” by the active DEF scheme (either permissive overreach [DEF POR], or blocked underreach [DEF BOR]).

Signal Send 2

Operates when the DEF sends either a permissive or blocking signal to the remote end (depending on the selected scheme)

DEF Protection

Indicates operation of the forward DEF element, either as a back-up trip or a DEF Aided Trip

DEF Rev Protection

Indicates operation of the reverse DEF element.

Sig Recvd 2 Flag

Operates on receipt of a DEF signal from the remote end.

UV1 Alarm

Indicates that the Level 1 Undervoltage element (UV1) has operated.

UV 2 Alarm

Indicates that the Level 2 Undervoltage element (UV2) has operated.

UV Trip

If the Undervoltage tripping is Enabled, this output will operate when the relay carries out an undervoltage trip. The Trip Output will also operate.

SOTF Operated

Indicates that a Switch-onto-fault Operation has occurred.

VTS Alarm

Operates when one or more phases of the Voltage Transformer fails.

Trip Output

This is used as the initiation for the tripping of the local circuit breaker. Depending on the settings of the relay I may be operated by any of the distance elements, Highset Overcurrent, Directional Earth Fault, Sensitive Earth Fault, energisation of the *Trip and Auto-Reclose* Status Input, Under/Overvoltage tripping.

Trip Reset

This output gives a reset pulse immediately after the trip output has dropped off internally. The pulse will remain high for either 100ms or the minimum relay operating time (if set higher).

Phase A Fault / Phase B Fault / Phase C Fault

Indicates the phase(s) involved in the fault condition

Earth-fault

Operates when the fault involved an earth-fault comparator.

Zone 1 / Zone 2 / Zone 3 / Zone 4

Indicates the Zone (s) which operated. Note these outputs are not starters – they will have the same time-delayed operation as the zones themselves.

Aided Trip

Operates when the relay operation was aided by the active distance scheme, i.e. indicates whether it was a simple time stepped distance trip or not.

Sig Recvd 1 Flag

Operates on receipt of a signal from the remote end distance protection. It will mirror the operation of the Status Input.

Carrier Guard

Operates when the *Carrier Guard* Status Input is energised because of a faulty signalling channel.

Power Swing Alarm

Operates when the System impedance characteristic has entered the Power Swing Detection Zone and remained there for longer than the *PSD Transit time*.

Delta Trip Cnt Alarm

Operate when the Delta trip counter has reached the target set in the CB Maintenance menu.

Total Trip Cnt Alarm

Operate when the Total trip counter has reached the target set in the CB Maintenance menu.

High Set

Operates when the relay has tripped due to operation of the Highset Overcurrent Element.

Overvoltage Alarm

Operates when the Overvoltage Alarm Element has picked up.

Overvoltage

Operates when the Overvoltage Trip Element has picked up.

SEF Alarm

Operates when the measured residual current has been greater than the SEF current setting for longer than the SEF Alarm Delay.

SEF Protection

Operates that the measured residual current has been greater than the SEF current setting for longer than the SEF Trip Delay. This will operate the main *Trip Output*.

Close Pulse

The output operated when a Close Pulse is issued to the breaker. This contact is wired to the CB close coil.

Trip Relay Reset

This output will give a pulse when the deadtime starts - i.e. once the breaker has opened and the trip initiation has disappeared. This is wired to the reset coils of the electrically reset trip relays.

Lockout

Operates when the autorecloser has locked out

A/R Out of Service

Operates whenever the autorecloser is "Out of service".

A/R In Service

Operates whenever the autorecloser is "in service".

A/R In Progress

This remains operated from the time the relay issues a trip until the end of the reclaim time. If the autorecloser locks out, this output will remain operated until the lockout condition is reset.

Live Line

Operates when the Line is considered to be Live, determined by the Line Live/Dead setting. See section 12 for application of these settings.

Live Bus

Operates when the Busbar is considered to be Live, determined by the Bus Live/Dead setting. See section 12 for application of these settings.

In Sync

Operates whenever the Busbar and Line voltages are in synchronism. Note that this output will be energised whenever the voltages are in synchronism, not just during a check sync operation.

CB Open

Operates when all 3 breaker Open status inputs (phases A, B and C) are high.

CB Closed

Operates when all 3 breaker Closed status inputs (phases A, B and C) are high.

CB Failed To Close

Operates if the breaker has not closed by the end of the Close Pulse.

System Split

Operates when a System Split occurs, i.e. when the phase angle difference between the Busbar and Line voltages becomes greater than the Split Angle setting.

Successful Close

This is a fleeting contact which operates at the end of the reclaim time.

CB Failed to Open

Operates if the breaker has not opened by the end of the *CB Failed to Open Delay* setting. The status (open or closed) of the breaker is determined from the breaker auxiliary contacts.

Check Sync Start

Operates at the start of the dead time and drops off at the end of the close pulse.

Sync In Prog Flag

Operates when the Busbar and Line voltages are live and the relay is checking the synchronising conditions. This drops off when the breaker closes.

Close Onto Fault

Operates if the relay re-trips during the close pulse.

Delta CB Count Alarm

The Delta CB Close counter is incremented every time the relay carries out a close operation. This output will operate when the Delta close counter reaches the target set in the CB maintenance Menu.

Total CB Count Alarm

The Total CB Close counter is incremented every time the relay carries out a close operation. This output operates when the Total CB Close counter reaches the target set in the CB maintenance Menu.

CB Not In Ser Alarm

The CB is Not In service if it is closed and the line is dead.

This Alarm operates if the breaker is undergoing maintenance work, as determined by the Live Line Check feature. While the breaker is Not In Service the relay will not initiate an autoreclose sequence.

CB Memory

This output is active if the CB is closed and the line is live. This output has a 2 second drop off delay and will still be active for 2 seconds after the opening of an 'In Service' CB. This output must be active for an Autoreclose sequence to start.

If the Line voltage was dead for 2 seconds (the CB memory time) prior to the breaker opening, the breaker is determined as being Not In Service. This output indicates that the condition of the Line voltage is being checked. It will drop off after a trip signal is sent to the breaker and the CB memory time has elapsed.

A/R Not Allowed

Operates if the breaker is tripped while it is Not In Service.

Input 1 Operated

Operates when the Status Input assigned to *Input 1* is energised.

Input 1 Not Operated

Operates when the Status Input assigned to *Input 1* is de-energised. This can be used as an inverter.

Input 2 Operated

Operates when the Status Input assigned to *Input 2* is energised.

Input 2 Not Operated

Operates when the Status Input assigned to *Input 2* is de-energised. This can be used as an inverter.

Input 3 Operated

Operates when the Status Input assigned to *Input 3* is energised.

Input 4 Operated

Operates when the Status Input assigned to *Input 4* is energised.

Input 5 Operated

Operates when the inputs assigned to *Input 5a*, *Input 5b*, *Input 5c* and *Input 5d* are all energised

Input 6 Operated

Operates when the inputs assigned to *Input 6a*, *Input 6b*, *Input 6c* and *Input 6d* are all energised

Timer 1 Operated

Operates when the *Timer 1* SI is energised for longer than the *Timer 1 Pickup Delay*. Remains operated until that initiating status input is de-energised.

Timer 2 Operated

This will operate when the *Timer 2* SI is energised for longer than the *Timer 2 Pickup Delay*. Remains operated until that initiating status input is de-energised.

Counter 1 Operated

This will operate when Counter 1 has received a set number of pulse inputs. The operating point for counter 1 is set as *Counter 1 Target* in the Reylogic Config menu.

Counter 2 Operated (as above)

This will operate when Counter 2 has received a set number of pulse inputs. The operating point for counter 1 is set as *Counter 2 Target* in the Reylogic Config menu.

Trip Circuit Fail

Operates when the SI assigned to Trip Circuit Fail operates.

OC Guard

Operates when the Over-current Guard picks up - i.e. when the current is below the OC Guard setting on all phases - and a block is being applied to the Distance protection. This output will be operated during normal load conditions and is therefore used mainly for test purposes.

Hand Reset Outputs

Output contacts can be programmed to latch in once they have operated. This feature allows the user to select the contacts to be latched. They can subsequently be re-set by operation of the re-set button or a control signal.

2.9 Output Operate Time Menu

R1-27 Min Operate Time (0.1-60s) 0.10 s

Allows a minimum dwell time for the relay contact to be closed for. Nominally set to the minimum operating time of 100ms

2.10 LED Configuration Menu

With the exception of the "Protection Healthy" item, this menu has the same relay outputs as the output Configuration menu and these can be used to energise any of the LED flags.

Self Reset LEDs

Any LED selected here will reset when the stimulus is removed and therefore will not latch.

2.11 Communications Menu

Station Address (0, 1, ... 254) 0

Defines the relay address number. When set to zero, the relay will not communicate.

IEC870 on port (COM1, COM2)

Defines the port which uses IEC 870 Communication protocol. The front port and the top rear fibre Optic ports are denoted COM2. When using a PC to communicate locally with the relay, this should be set to COM2.

Note that this should not be confused with the comms port on the PC.

COM1 Baud Rate (75, 110, 300, 600, 1200, 2400, 4800, 9600, 19200, 38400, 57600, 115200)

Defines the Baud rate used by the COM 1 of the relay to communicate with an external device. The relay and the external device must both be using the same baud rate in order for communications to be established.

COM1 Parity (Even, Odd, None)

Defines the type of Parity used by the COM 1 of the relay when communicating with an external device. The relay and the external device must both be using the parity in order for communications to be established.

COM1 Line Idle (Light On, Light Off)

For the Fibre Optic port. Defines whether the fibre optic light will be ON or OFF when the line is idle.

COM1 Data Echo (Off, On)

This setting must be switched on, to enable the relay to pass data around a ring system. If a number of relays are connected together, the data echo feature must be switched on to allow data transfer. When communicating with a single relay it may be easier to switch this setting to OFF.

COM2 Baud Rate (75, 110, 300, 600, 1200, 2400, 4800, 9600, **19200**, 38400, 57600, 115200)

Defines the Baud rate used by the COM 1 of the relay to communicate with an external device. The relay and the external device must both be using the same baud rate in order for communications to be established.

COM2 Parity (Even, Odd, **None**)

Defines the type of Parity used by the COM 2 of the relay when communicating with an external device. The relay and the external device must both be using the parity in order for communications to be established.

COM2 Line Idle (Light On, **Light Off**)

For the Fibre Optic port. Defines whether the fibre optic light will be ON or OFF when the line is idle.

COM2 Data Echo (Off, On)

This setting must be switched on, to enable the relay to pass data around a ring system. If a number of relays are connected together, the data echo feature must be switched on to allow data transfer. When communicating with a single relay it may be easier to switch this setting to OFF.

COM2 Direction (**Auto-Detect**, Rear Port, Front Port)

The relay has two external connections to COM port 2 – via the rear fibre optic connection or via the front RS232 connection. This defines which port is used. When set as auto-detect it will switch between ports depending on the connected devices.

2.12 CB Maintenance Menu

Total CB Trip Count Alarm (OFF, 1 – 9999)

Sets the number of trip operations after which the *Total CB Trip Cnt* output will operate.

Delta CB Trip Count Alarm (OFF, 1 – 9999)

Sets the number of trip operations after which the *Delta CB Trip Cnt* output will operate.

Total CB Close Count Alarm (1, 2, ... 999) 100

Sets the number of close operations after which the *Total CB Close Cnt* output will operate.

Delta CB Close Count Alarm (1, 2, ... 999) 20

Sets the number of close operations after which the *Delta CB Close Cnt* output will operate.

Reset Total CB Trip Count NO

Selecting this setting to YES will reset the counter. It will automatically reset to NO.

Reset Delta CB Trip Count NO

Selecting this setting to YES will reset the counter. It will automatically reset to NO.

Reset Total CB Close Count NO

Selecting this setting to YES will reset the counter. It will automatically reset to NO.

Reset Delta CB Close Count NO

Selecting this setting to YES will reset the counter. It will automatically reset to NO.

2.13 Data Storage Menu

Pre-trigger Storage (10 ... 90%) 20 %

Sets the proportion of pre and post fault which will be stored in the waveform record.

Record Duration (10x1, 5x2, 2x5, 1x10) 10 Rec x 1 Sec

The relay can record 10 seconds of data. Normally the relay is arranged to store 1 a total of ten 1-second records. The size of those records can be changed, though the total length of data stored will not be changed. Thus the relay can store either ten 1-second records, five 2-second records, two 5-second records or one tens second record. Whenever a trip occurs the relay will trigger waveform storage and the oldest record in the memory will be overwritten.

2.14 Fault Locator Menu

Pos Seq Line Impedance (0.1 – 250 Ω) 10 Ω

This is the positive sequence impedance of 100% of the line.

Sec'y Z+ per unit distance (0.1 – 250 Ω) 0.500 Ω

Defines the secondary positive sequence impedance per mile or kilometre.

Display distance as (*Percent, Kilometres, Miles*)

Defines whether the distance is displayed as a distance or as a percentage of the Pos Seq Line Impedance setting.

Fault Locator (*Enabled, Disabled*)

Allows the fault locator to be enabled or disabled.

Menu Structure

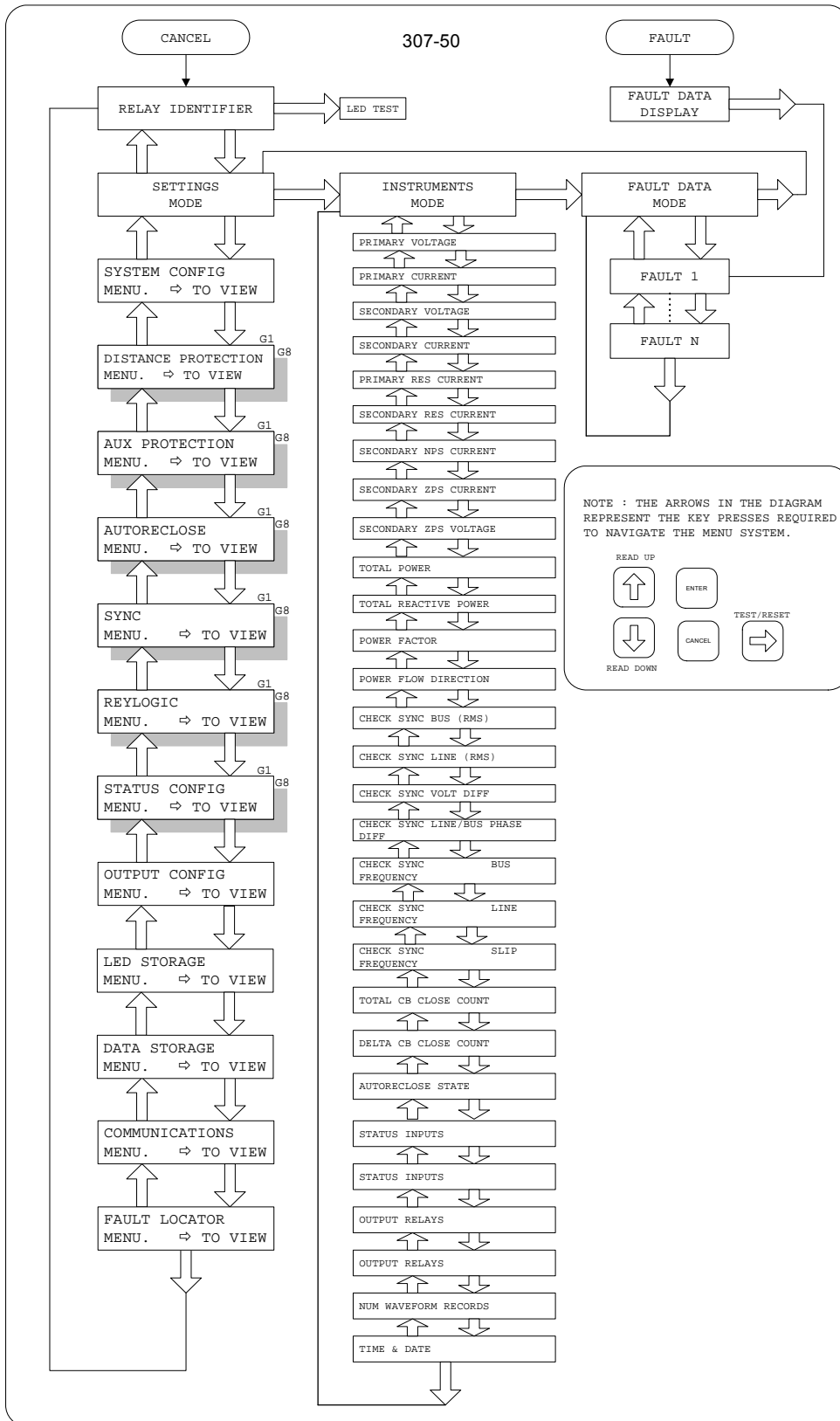

7SG163 Ohmega 300 Series

7SG163 Protection Relay

Document Release History

This document is issue 2010/02. The list of revisions up to and including this issue is:
Pre release

2010/02	Document reformat due to rebrand

The copyright and other intellectual property rights in this document, and in any model or article produced from it (and including any registered or unregistered design rights) are the property of Siemens Protection Devices Limited. No part of this document shall be reproduced or modified or stored in another form, in any data retrieval system, without the permission of Siemens Protection Devices Limited, nor shall any model or article be reproduced from this document unless Siemens Protection Devices Limited consent.

While the information and guidance given in this document is believed to be correct, no liability shall be accepted for any loss or damage caused by any error or omission, whether such error or omission is the result of negligence or any other cause. Any and all such liability is disclaimed.

Contents

1	Introduction.....	3
2	Technical Specification.....	3
3	Additional Features.....	4
4	Indication.....	5
5	Output contacts	5
6	Status inputs.....	5
7	Optional Features	5
8	Performance Specification.....	6
9	Output Contact Performance	9
10	Auxiliary Energizing Quantity.....	9
11	Environmental Withstand.....	10

1 Introduction

The following document defines the technical and performance specification of the standard features in this series of relays. Optional features are described in the last part of the document.

Performance Data to:
IEC60255-6, IEC60255-6A and IEC60255-16.

2 Technical Specification

2.1 Rated Current

Three possible current ratings can be obtained by programming the correct rating.
1, 2 or 5 Amps

2.2 Rated voltage

The relay requires a four wire voltage system, phase A, B, C & N
Rated voltage 63.5 Volts ac Phase - N

2.3 Rated Frequency

Two operating frequencies are available
Frequency - 50 or 60Hz

2.4 Characteristic Angle

The characteristic angle can be adjusted to suit any composition of line or cable circuit. This angle is used for all zones.
Angle - 0° - 90° in 5° steps

2.5 Zone impedance settings

Distance relays usually quote the boundary of performance in terms of SIR (System Impedance Ratio) plotted against the accuracy of the relay. This is a powerful method of describing the relays performance.

Adjustment of the positive sequence zone impedance is made by the menu selection. Each zone has the same setting range

Rating	Zone Range
1A	0.1-250 Ohm
2A	0.1-125 Ohm
5A	0.1-50 Ohm

1A	0.1-250 Ohm
2A	0.1-125 Ohm
5A	0.1-50 Ohm

Any zone is selectable within the setting range specified. Settings can be applied in step ranges where the step does not exceed 2% of the range. The protection provides the option of using the 5A (or 2A) tap on a 1A CT in order to attain a lower range.

2.6 Residual Compensation

The residual compensation applies to all zones.

Z_0/Z_1 0-10 in steps of 0.01
 Z_0 angle – 0 to 355° in steps of 5°

2.7 Zone 4 Settings

The zone 4 element is a reverse of zone one and has independent impedance settings with the same range as zone 1. The angle is a mirror image of the forward fault angle.

2.8 Timers

2.8.1 Distance Function Zone Timers

Zone Timers (Z1T through Z4T)
0 to 10 s in steps of 10ms

2.8.2 Additional Timers

Timing functions for scheme operation and other protection functions are available. These are model specific and the relay setting section must be consulted for the individual timing range and step setting.

2.9 Measuring Elements

2.10 Zone 1 and Zone 2 elements

Both zone 1 and zone 2 have six measuring elements each. Three are for phase fault and three are for earth fault. Each element is independent giving the relay full scheme capabilities. The characteristic shapes available are circular polarised MHO for phase and earth fault and an option of quadrilateral characteristic for earth fault.

2.11 Zone 3 elements

Zone three has three phase fault phase fault elements and three earth fault elements The characteristic shapes available for both phase and earth fault are:-

Circular polarised MHO forward
Circular polarised MHO reverse
Circular offset MHO

Phase fault characteristics have the additional feature to allow for load encroachment and can be shaped.

An option of quadrilateral characteristic for earth fault is also available.

2.12 Zone 4 elements

This provides a reverse polarised MHO characteristic or E/F quadrilateral zone and is normally used in schemes which require reverse fault coverage or blocking schemes.

3 Additional Features

3.1 High Set Overcurrent

A High Set transient free overcurrent element is available this can be selectable to Instantaneous or Definite Time Lag (DTL). It has the following range of settings:-

0.1 – 6.0I_n in steps of 0.1
6.25 – 35I_n in steps of 0.25
0 – 1.0 s in steps of 0.001 s

3.2 Voltage Transformer Supervision (VTS)

Modes of operation:-

Alarm only

Alarm & inhibit

Inhibit can be selected to either block operation of phase & earth fault elements or to only block operation of earth fault elements during loss of voltage conditions.

VTS I_{res} level 0.05 – 2.0 I_n in steps of 0.1I_n
VTS V_{res} level 1 – 100V

Output configuration:-

Instantaneous operation/reset
Minimum delayed alarm 100ms

Delayed alarm/reset 0.1 – 60s

3.3 Switch On To Fault

Two arrangements provide instantaneous tripping when switching on to a bolted three-phase fault.

- a) D.C. Line check
This arrangement is energised from the circuit breaker closing circuit and allows instantaneous zone 3 coverage for a period of 400ms after energising the line.
- b) A.C. Line check
This arrangement is not dependant on the circuit breaker closing circuit and allows instantaneous zone 3 coverage for a period of 200 ms after the line is energised. After the line is de-energised the line check resets after the programmed time delay. Line de-energisation is detected by three-phase pole-dead logic, while the line check measurement uses this in conjunction with phase current detectors.

3.4 Power Swing

The power swing element has a circular or rectangular offset element that consists of two concentric characteristics. The inner zone impedance is set between the ranges of 0.1 – 250 Ohms and the outer zone has a setting, which is a multiplier of the inner zone. This is set between 1.05 and 2x. The blocking detector uses a transition time between the inner and outer boundaries this is adjustable between 0 – 1000 ms in 5 ms steps.

The power swing blocking function will be released during an unsymmetrical fault.

The blocking can be arranged to block any zone.

3.5 Fault Locator

The fault locator is triggered by the fault recorder in the event of a general trip. It uses information from the waveform record associated with the fault to determine both the fault type and the line impedance between the relay and the fault location, ignoring any fault resistance. This information is then displayed as part of the relay fault record. By default, the location is displayed as a percentage of the positive sequence line impedance. This can be set in the range 0.1 – 250 ohms in magnitude, and uses the relay line angle as set for the distance protection.

The fault location can be displayed instead as a distance in miles or kilometres by selecting the required display units, and by setting an appropriate value for the secondary positive sequence impedance per unit length. This can be set in the range 0.001 to 5.000 ohms.

4 Indication

Indication is provided by 32 red LEDs; these are fully configurable to the user. Adjacent to each column of LEDs is a removable strip on which the LED function can be printed, allowing comprehensive fault indication. It is possible to print the indicator strip in languages other than English. The LCD provides further fault indication and can be used for programming the relay. See section 1 for a detailed explanation for the programming of the relay.

5 Output contacts

As with the indication the output contacts are fully programmable the basic I/O module has 5 output contacts three of which are change over. Additional modules can be added to provide more contacts. These are added in-groups of eight.

6 Status inputs

As with the indication and output contacts the status inputs are fully programmable the basic I/O module has 3 status inputs these can be set to high speed for signalling. Additional modules can be added to provide more inputs. These are added in-groups of eight.

7 Optional Features

7.1.1 Directional Earth Fault Setting Range

Polarising Quantity
1V polarising voltage

Characteristics:
DTL, IEC-NI, IEC-VI, IEC-EI, IEC-LTI, ANSI-MI, ANSI-VI, ANSI-EI.

DEF OverCurrent Setting
0.05 x I_n to 1.10 x I_n in steps of 0.05

DEF IDMTL Characteristic setting
0.05 x I_n – 2.5 x I_n in 0.05 steps.

DEF Characteristic Angle Setting
0° to 85° lagging in steps of 5°

7.1.2 Directional Earth Fault Timer

DEF DTL Timer (DT1)
0 to 5 secs in steps of 10ms

DEF IDMTL Time Multiplier:
0.025-1.6 in steps of 0.025

RESET Characteristics:
DTL, Instantaneous, ANSI Decaying.

8 Performance Specification

Throughout the performance specification accuracy statements are made at reference conditions.
These reference conditions are as follows:

Reference Conditions

General	IEC60255 Parts 6, 6A & 16
Auxiliary Supply	Nominal
Frequency	50 or 60Hz
Characteristic Line Angle	75°
Ambient Temperature	20°C

Zone 1 impedance 6.0 Ohms
Zone 2 impedance 6.0 Ohms
Zone 3 impedance 6.0 Ohms
Zone 4 impedance 6.0 Ohms

Neutral impedance Z_0/Z_1 ratio 2.5
 Z_0 angle = 75°

8.1 Accuracy General

Transient Overreach of Distance Protection for X/R = 35	±5%
Disengaging Time	30ms

Note: Output contacts have a minimum dwell time of 100ms, after which the disengaging time is as above.

8.2 Accuracy Influencing Factors

Temperature

Ambient range	-10°C to +55°C
Variation over range	≤ 5%

Frequency

Range	47Hz to 52Hz 57Hz to 62Hz
Setting variation	≤ 5%
Operating time variation	≤ 5%

Harmonic Content

Harmonic content of waveforms	Frequencies to 550Hz
Operating time variation	≤ 5%

Auxiliary DC Supply – IEC 60255-11

Allowable superimposed ac component	≤ 12% of DC voltage
Allowable breaks/dips in supply (collapse to zero from nominal voltage)	≤ 20ms

8.3 Distance Function Reach

Reach Accuracy, ± 5% or 0.1 Ω which ever is greater up to an SIR of 30

Reach Accuracy, ± 10% or 0.1 Ω which ever is greater, from an SIR of 30 to an SIR of 60

Characteristic Angle Setting ≤ ±3°

Zone Timers (Z1T through Z4T)

≤ ±1% or ±10ms (whichever is greater)

8.4 Departure from Reference Angle

The nominal setting of the relay at angles other than the reference angle depends upon the characteristic shape. In general terms the impedance setting (Z) at any angle (Φ) can be expressed in terms of the nominal setting (Z_N) at the reference angle (Φ_N) as follows,

$$Z = Z_N f(\Phi)$$

Where $f(\Phi)$ is the equation defining the characteristic. Using this method the variation in characteristic shape can be simply specified in terms of class accuracy and the deviation from the reference angle. At nominal voltage the variations are listed below.

Circular characteristic

Φ_N – Nominal characteristic angle

Z_N – Nominal impedance setting

Z_N^1 – Measured impedance at nominal angle Φ_N

For $\Phi = \Phi_N \pm 10^\circ$

$$Z = Z_N^1 * \cos(\Phi_N - \Phi) \pm 0.05Z_N$$

At other angles within the limits $90^\circ \geq \Phi \geq 0^\circ$

$$Z = Z_N^1 * \cos(\Phi_N - \Phi) \pm 0.1Z_N$$

The departure from reference angle is for a three phase balanced condition.

The above variations can also be applied to offset characteristics by transferring the origin.

8.5 Transient overreach

The class index plus an error not exceeding the class index.

8.6 Departure from reference setting

The class index plus an error not exceeding the class index.

8.7 Departure from reference frequency

Over the range of 47 – 52 Hz (50Hz nominal) or 57 – 62 Hz (60Hz nominal), the variations in accuracy are the class index plus an error not exceeding the class index.

8.8 Departure from reference temperature

The variations in accuracy over the operating temperature range is the class index plus an error not exceeding the class index.

8.9 High Set Overcurrent Function

Operating Current
 $\leq \pm 5\%$ of setting

Reset current
 $> 95\%$ of operating current

Overcurrent Time (OCT)
 $\leq \pm 1\%$ or $\pm 10\text{ms}$ (whichever is greater)

8.10 Forward and Reverse Directional Earth Fault Functions

Operating Current
 $\leq \pm 5\%$ of setting

Reset Current
 $> 95\%$ of operating current

Definite Time Lag
 $\leq \pm 1\%$

DEF DTL Timers (DEFF, DEFR)
 $\leq \pm 1\%$ or $\pm 5\text{ms}$ (whichever is greater)

8.11 Power Swing (PS) Impedance Variation Setting Range

Characteristic or Impedance Variation
 $\leq \pm 5\%$ error

8.12 Timing

Figures 1, 2 and 3 shown typical timing curves.

8.13 Fault locator

Accuracy is dependant upon circuit configuration and power flow conditions.

8.14 THERMAL WITHSTAND

Continuous and Limited Period Overload

AC Current Inputs

12A	Continuous
15A	for 10 minutes
30A	for 2 minutes
AC Voltage Input $-3.5V_n$	Continuous

Short Term Overload

340A	for 1 sec
240A	for 2 sec
625A	for 1 cycle (Peak)

AC Voltage Inputs

3.5Vn	Continuous
-------	------------

8.15 BURDENS

Current Circuits

	AC Burden (VA per phase)
1A tap	0.025
2A tap	0.1
5A tap	0.625

Voltage Circuits

0.01VA per phase

NB. Burdens and impedances are measured at nominal rating.

D.C. Burden

	DC Burden (watts)
Quiescent (Typical)	15
Max	27

9 Output Contact Performance

Contact rating to IEC 60255-0-2.

Carry continuously 5A ac or dc

Make and Carry

(limit $L/R \leq 40\text{ms}$ and $V \leq 300\text{ volts}$)

for 0.5 sec	20A ac or dc
for 0.2 sec	30A ac or dc

Break

(limit $I \leq 5\text{A}$ or $V \leq 300\text{ volts}$)

ac resistive	1250VA
ac inductive	250VA @ PF ≤ 0.4
dc resistive	75W
dc inductive	30W @ $L/R \leq 40\text{ ms}$ 50W @ $L/R \leq 10\text{ ms}$

Minimum number of operations	1000 at maximum load
Minimum recommended load	0.5W, limits 10mA or 5V

10 Auxiliary Energizing Quantity

DC Power Supply

	Nominal	Operating Range
VAUX	30V	24V to 37.5V dc
VAUX	50/110/125V	37.5V to 137.5V dc
VAUX	220/250/260V	175V to 286V dc

DC Status Inputs

Nominal Voltage	Operating Range
30/34	18V to 37.5V
48/54	37.5V to 60V
110/125	87.5V to 137.5V
220/250	175 to 286V

Status Input Performance (30V and 48V)

Minimum DC current for operation	10mA
Reset/Operate Voltage Ratio	$\geq 90\%$

Status Input Performance (110V and 220V)

Minimum DC current for operation	1mA
Reset/Operate Voltage Ratio	≥ 90%

NB Status operating voltage need not be the same as the main energising voltage. 48/54 volt rated status inputs can be supplied with external dropper resistors, for use with 110V or 220V dc supplies, as follows:-

Status Input External Resistances

Nominal Voltage	Resistor Value; Wattage
110/125V	2k7 ± 5% ; 2.5W
220/250V	8k2 ± 5% ; 6.0W

Two types of status inputs are provided, viz:-

- a) High speed status inputs.

Typical response time	<5ms
Typical drop off time	<5ms
Typical response time when programmed to energise an output relay contact	<10ms

- b) Scheme status inputs. These status inputs will not respond to either 250V RMS 50/60 Hz applied for 1 second or to the discharge of a 10µF capacitor charged to maximum DC auxiliary supply voltage.

Typical response time	<25ms
Typical Drop off time	<25ms
Typical response time when programmed to energise an output relay contact	<30ms

11 Environmental Withstand

Temperature - IEC 6068-2-1/2

Operating range	-10°C to +55°C
Storage range	-25°C to +70°C

Humidity - IEC 6068-2-3

Operational test	56 days at 40°C and 95% RH
------------------	----------------------------

Transient Overvoltage –IEC 60255-5

Between all terminals and earth or between any two independent circuits without damage or flashover	5kV 1.2/50µs 0.5J
---	-------------------

Insulation - IEC 60255-5

Between all terminals and earth	2.0kV rms for 1 min
Between independent circuits	2.0kV rms for 1 min
Across normally open contacts	1.0kV rms for 1 min

High Frequency Disturbance -
IEC 60255-22-1 Class III

	Variation
2.5kV Common (Longitudinal) Mode	≤ 3%
1.0kV Series (Transverse) Mode	≤ 3%

Electrostatic Discharge -
IEC 60255-22-2 Class III

	Variation
8kV contact discharge	≤ 5%

Radio Frequency Interference -
IEC 60255-22-3 Class III

	Variation
--	-----------

20MHz to 1000MHz, 10V/m	≤ 5%
-------------------------	------

Fast Transient – IEC 60255-22-4 Class IV

	Variation
4kV 5/50ns 2.5kHz repetitive	≤ 3%

Vibration (Sinusoidal) – IEC 60255-21-1 Class 1

		Variation
Vibration response	0.5gn	≤ 5%
Vibration endurance	1.0gn	≤ 5%

Shock and Bump – IEC 60255-21-2 Class 1

		Variation
Shock response	5 gn 11ms	≤ 5%
Shock withstand	15 gn 11ms	≤ 5%
Bump test	10 gn 16ms	≤ 5%

Seismic – IEC 60255-21-3 Class 1

		Variation
Seismic Response	1gn	≤ 5%

Mechanical Classification

Durability	In excess of 10 ⁶ operations
------------	---

7SG163 Ohmega 300 Series

7SG163 Protection Relay

Document Release History

This document is issue 2010/02. The list of revisions up to and including this issue is:
Pre release

2010/02	Document reformat due to rebrand

The copyright and other intellectual property rights in this document, and in any model or article produced from it (and including any registered or unregistered design rights) are the property of Siemens Protection Devices Limited. No part of this document shall be reproduced or modified or stored in another form, in any data retrieval system, without the permission of Siemens Protection Devices Limited, nor shall any model or article be reproduced from this document unless Siemens Protection Devices Limited consent.

While the information and guidance given in this document is believed to be correct, no liability shall be accepted for any loss or damage caused by any error or omission, whether such error or omission is the result of negligence or any other cause. Any and all such liability is disclaimed.

Contents

1	Introduction	3
2	Connection Specification and Relay Settings.....	4
2.1	Recommended cable	4
2.2	Connection Method	4
2.3	Transmission Method.....	4
2.4	Transmission Rate	4
2.5	Line Idle Setting	4
2.6	Parity Setting.....	4
2.7	Address Setting.....	4
2.8	Modems	4

1 Introduction

The Communication Interface module in the relay incorporates the following ports:

- 1 An IRIG-B input for time synchronisation
- 2 A pair of fibre optic ST connectors for transmit and receive communications (port 1).
- 3 A pair of fibre optic ST connectors as for (2) but intended for transmit and receive communications to a substation SCADA or integrated control system and using IEC 60870-5-103 protocol. (Port 2B). The same port can be accessed instead through an RS232 connector mounted on the relay fascia. (Port 2A). This provides facilities for access to the relay from a lap-top or PC used for commissioning or interrogating relays on site.

See the Installation section of this manual, for further information.

The following text gives details of connecting the IEC 60870-5-103 Complaint Informative Communication Interface to a control system or interrogating computer. To access the interface, appropriate software such as Reydisp Evolution is needed within the control system or the interrogating computer.

2 Connection Specification and Relay Settings

This section defines the connection medium as defined by IEC 870-5-103. Appendix A shows some typical communication connections.

2.1 Recommended cable

200µm Plastic Coated Silica (PCS) or 6215/125µm glass. All cables should be terminated with 2.5mm ST connectors.

2.2 Connection Method

Communication networks can be connected in star or optical ring format. The Optical Ring architecture requires data to be passed from one relay to the next, therefore when using this method all relays in the ring must have **Data Echo = ON** selected in the Communications Interface menu of the settings list. Otherwise this setting is to be **Data Echo = OFF**. Appendix A illustrates a number of network arrangements.

2.3 Transmission Method

Half Duplex serial asynchronous transmission. In IEC 60870-5-103 the line idle state is defined as **Light On**. This can alternatively be selected as **Light Off** in the Communications Interface menu of the settings list if required for use with alternate hardware (See Section 2.5).

2.4 Transmission Rate

Rates of **19200, 9600, 4800, 2400, 1200, 600, 300, 150, 110** and **75** bits per second (BPS) are provided. Only **19200** and **9600** BPS are defined in IEC 60870-5-103, the additional rates are provided for local or modem communications.

2.5 Line Idle Setting

The line idle setting must be set to be either **ON** or **OFF** to be compatible with the device connected to the relay. IEC 60870-5-103 defines a line idle state of **Light On**. Unless the device connected to it has a compatible fibre optic port Sigma 4, a converter to connect it to a standard RS232C electrical interface is needed.

Alternately, it may be connected via a **Sigma 3 Dual RS232 Port** or **Sigma 1 Passive Fibre Optic Hub**.

The Sigma 3 Dual RS232 port provides a Fibre-Optic interface to a relay and 2 RS232 Ports. The RS232 system port is typically connected to a control system. Both this and the Fibre Optic port would usually be hidden from view inside a panel. The second RS232 port is local port. When it is in use the system port is automatically disabled. The Dual port device has an internal link to define whether the fibre optic port will operate as **Light On** or **Off**. Default is **Off**.

The Sigma 1 Passive Fibre Optic Hub provides fibre optic interfaces for up to 29 relays. It has a fibre optic port to the control system and multi relay connect. Each of the 30 fibre optic ports can be configured for **Light On** or **Off** operation. Default for all is **Off**.

2.6 Parity Setting

IEC 60870-5-103 defines the method of transmission as using **Even Parity**, however, in some instances an alternative may be required, this option allows the setting of parity to **None**.

2.7 Address Setting

The remaining setting on the communications menu is the Address setting. The address of the relay must be set to a value between 1 and 254 inclusive before communication can take place. Setting the address to zero disables communications to the relay, although if it is in an optical ring it will still obey the Data Echo setting. All relays in an optical ring must have a unique address. Address 255 is reserved as a global broadcast address.

2.8 Modems

The communications interface has been designed to allow data transfer via modems. However, IEC 60870-5-103 defines the data transfer protocol as an 11 bit format of 1 start, 1 stop, 8 data and Even Parity which is a mode most commercial modems do not support. High performance modems, for example, Sonix (now 3Com) Volante and Multi Tech Systems MT series will support this mode, but are expensive. For this reason a parity setting (see section 2.6) to allow use of easily available and relatively inexpensive commercial modems has been provided.

The downside to this is that the data security will be reduced slightly, and the system will not be compatible with true IEC60870 control systems.

2.8.1 Connecting a modem to the relay(s)

RS232C defines devices as being either Data Terminal Equipment (DTE) e.g. Computers, or Data Communications Equipment (DCE) e.g. Modems, where one is designed to be connected to the other. In this case two DCE devices (the Modem and the Fibre-Optic Converter converter) together via a Null Terminal connector which switches various control lines. The Fibre-Optic converter is then connected to the relay network Tx to Relay Rx and Rx to Relay Tx.

2.8.2 Setting the Remote Modem

The exact settings of the modem are dependent on the type of modem preset. Although most support the basic Hayes 'AT' command format, different manufacturers use different commands for the same functions. In addition, some modems use DIP switches to set parameters, others are entirely software configured.

Before applying the following settings it is necessary to return the modem to its factory default settings, to ensure it is in a known state.

There are several factors which must be set to allow remote dialing to the relays. The first is that the modem at the remote end must be configured as Auto Answer. This will allow it to initiate communications with the relays. Next the user should set the data configuration at the local port, i.e. baud rate and parity, so that communication will be at the same rate and format as that set on the relay; and the error correction is disabled.

Auto-Answer usually requires 2 parameters to be set. The auto answer setting should be switched on and the number of rings after which it will answer. The Data Terminal Ready (DTR) settings should be forced on. This tells the modem that the device connected to it is ready to receive data.

The parameters of the modem's RS232C port need to be set to match those set on the relay, set baud rate and parity to be the same as the settings on the relay, and number of data bits to be 8 and stop bits 1. Note, although it may be possible to communicate with the modem at say 19200 BPS it may only be able to transmit over the telephone lines at 14400. Therefore a baud rate setting that the modem can transmit should be chosen. In this case, there is no 14400 BPS on the relay choose the next lowest i.e. 9600 BPS.

Since the modems need to be transparent, simply passing on the data sent from the controller to the device and vice versa, the error correction and buffering must be turned off.

In addition if possible force the Data Carrier Detect (DCD) setting to ON as this control line will be used by the Fibre-Optic converter.

Finally these settings should be stored in the modem's memory for power on defaults.

2.8.3 Connecting to the remote modem

Once the remote modem is configured correctly, should it be possible to dial into it using standard configuration from a local PC. As the settings on the remote modem are fixed, the local modem should negotiate with it on connecting and choose suitable matching settings. If it does not, set the local modem to mimic the settings of the remote modem described above.

7SG163 Ohmega 300 Series

7SG163 Protection Relay

Document Release History

This document is issue 2010/02. The list of revisions up to and including this issue is:
Pre release

2010/02	Document reformat due to rebrand

The copyright and other intellectual property rights in this document, and in any model or article produced from it (and including any registered or unregistered design rights) are the property of Siemens Protection Devices Limited. No part of this document shall be reproduced or modified or stored in another form, in any data retrieval system, without the permission of Siemens Protection Devices Limited, nor shall any model or article be reproduced from this document unless Siemens Protection Devices Limited consent.

While the information and guidance given in this document is believed to be correct, no liability shall be accepted for any loss or damage caused by any error or omission, whether such error or omission is the result of negligence or any other cause. Any and all such liability is disclaimed.

Contents

1	Introduction	3
2	Current Transformer Requirements.....	3
3	Determination Of Relay Settings	4
3.1	Information Required For The Setting Calculations	4
3.2	Distance Protection Settings	4
3.3	Zone 1 setting	5
3.4	Zone 2 Setting.....	5
3.5	Zone 3 Setting.....	6
3.6	Zone 4 Setting.....	6
	APPENDIX A Status Inputs	7

1 Introduction

The Ohmega family of Digital Distance Relays give full scheme protection with independent measurements for every zone and fault loop. Impedance starting elements are not required. Optional features provide a full range of protection functions supplements by control, metering, data storage and fibre optic data communication capabilities.

The relays can be applied to either overhead line or cable feeders and, depending on the availability and type of teleprotection channels available, can be configured to provide unit protection in a number of different models.

2 Current Transformer Requirements

The current transformers used with Ohmega relays should be class TPS to IEC 46-6 (ie BS3938 class x). The CT's should have a knee point voltage V_k as follows:-

Phase Fault

$$V_k \geq K \cdot \frac{I_p}{N} \left(1 + \frac{X_p}{R_p} \right) (0.03 + R_{ct} + R_l)$$

Earth Fault

$$V_k \geq K \cdot \frac{I_e}{N} \left(1 + \frac{X_e}{R_e} \right) (0.06 + R_{ct} + 2R_l)$$

Where:

I_p = phase fault current calculated for X_p/R_p ratio at the end of zone 1.

I_e = earth fault current calculated for X_e/R_e ratio at the end of zone 1.

N = C.T. ratio

X_p/R_p = power system resistance to reactance ratio for the total plant including the feeder line parameters calculated for a phase fault at the end of zone 1.

X_e/R_e = similar ratio to above but calculated for an earth fault at the end of zone 1.

R_{ct} = C.T. internal resistance

R_l = lead burden, C.T. to Ohmega terminals

K = factor chosen to ensure adequate operating speed and is < 1 . K is usually 0.5 for distribution systems, a higher value is chosen for primary transmission systems. Reyrolle Protection should be consulted.

Both V_k values should be calculated and the higher value chosen for the C.T. to be used.

3 Determination Of Relay Settings

3.1 Information Required For The Setting Calculations

To match a distance protection relay to a feeder the following data must be known:-

- Positive sequence of the feeder Z_1 ohm/km
- Zero sequence impedance of the feeder Z_0 ohms/km
- Length of protected feeder
- Maximum and minimum fault current infeed at relaying point
- Current transformer ratio
- Voltage transformer ratio
- Length of adjacent lines which are partially or wholly included within the Zone 2, 3 or 4
- The position, rating and reactance of any power transformers connected to the system within the zone 4 forward and reverse impedance reach.
- Fault current infeeds at tee-off points or remote substations
- Fault clearance time on circuits within the Zone 2 and Zone 3 and Zone 4 impedance reaches
- Maximum load current
- Phase angle of line impedance
- Maximum residual capacitance current at the relaying points for earth faults in adjacent circuits
- Minimum residual current available to operate the earth fault detector

3.2 Distance Protection Settings

The first settings in the menu are common for all zones. The relay will use a time-stepped scheme by default. All relay schemes are detailed in Section 3 of this manual.

3.2.1 Overall Settings

The first settings made in the distance protection menu apply to all zones of protection. The CT secondary, is set as set as 1A, 2A or 5A depending on the CT rating. The line angle is the angle of the positive sequence impedance of the feeder.

3.2.2 Residual Compensation Settings.

The Zone reach settings for each zone of protection are made in terms of the positive sequence impedance of the transmission line. To allow the earth fault comparators to correctly take account of the fault loop impedance, the ratio of voltage to current is multiplied by a factor of K_N+1 , where K_N is the Residual Compensation Factor, which

may be determined from the following equation;

$$K_N = \frac{1}{3} \left(\frac{Z_0}{Z_1} - 1 \right)$$

Settings made on the relay are:

EF Comp Z_0/Z_1 ratio. This is simply the ratio between the zero and positive sequence impedances.

EF Comp Z_0 Angle. This is simply the angle of the zero sequence impedance.

The relay automatically calculates the residual compensation from these two settings.

3.3 Zone 1 setting

Normal practice is to make the Zone 1 setting equal to 80% of the positive sequence impedance of the protected feeder to allow for the inherent errors in estimating line impedance's and possible errors in voltage and current transformers.

Settings other than 80% are possible, but to ensure that the relay does not overreach into the remote busbars, care is necessary when choosing such settings. It is particularly important to ensure that the impedance of the protected feeder is accurately known and the mutual effects due to adjacent feeders are considered for all known operating conditions. On a feed-feeder the Zone 1 impedance setting should be approximately 80% of the positive sequence impedance from the relaying point to the nearer of the remote ends.

On lines with tee-off transformers connected to them, the Zone 1 setting can extend beyond the tee-off point, provided it does not reach beyond the windings of any transformer. If a transformer is earthed on the line side, it can supply zero sequence current which is equivalent to an infeed, and should be considered when choosing the Zone 1 setting.

On feeder transformers, Zone 1 should be set to cover at least 1.2 times the positive sequence impedance of the feeder. It should not, however, exceed 0.8 times the sum of the feeder impedance and the transformer impedance.

Having decided upon the impedance setting required, the relay setting is determined as follows:- Zone 1

$$\text{Setting} = L_1 \times \frac{C}{V}$$

where: L_1 = required Zone 1 reach in primary positive sequence ohms.
 C = protection current transformer ratio
 V = protection voltage transformer ratio

3.4 Zone 2 Setting

Zone 2 setting should be at least 1.2 times the positive sequence impedance of the protected feeder. For teed feeders the setting should be at least 1.2 times the impedance to the most remote end, the effect of infeeds at the tee points being allowed for as shown in choose the setting for maximum infeeds, but take care it does not encroach onto the second zone of distance protection of adjacent feeders for minimum fault infeed conditions.

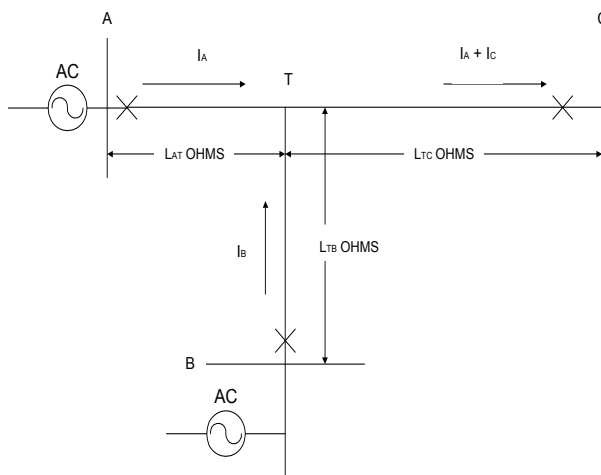

On lines with tee-off transformers connected to them, the tee-off transformers can supply zero sequence current if they are earthed on the line side. This is equivalent to an infeed as indicated and must be taken into account when choosing the Zone 2 setting. Normally the Zone 2 reach will be set so that it does not extend beyond a power transformer, but should a particular application require an extended reach of this nature, then care should be taken to grade the protection accordingly.

The Zone 2 setting is obtained by adjusting the impedance setting.

$$\text{Zone 2 Setting at A} \geq 1.2 \left[L_{AT} + L_{TC} \left(\frac{I_A + I_B}{I_A} \right) \right]$$

3.5 Zone 3 Setting

The Zone 3 setting will depend upon the system adjacent to the protected feeder and the amount of back-up protection required. To give back-up protection on the protected feeder, the Z3 should be at least equal to and not less than the Z2 setting.

The Zone 2 and Zone 3 timers are normally set to give a grading margin between the zones.

On lines with tee-off transformers, the transformers can supply zero sequence current if they are earthed on the line side. This is equivalent to an infeed as indicated in and should be considered when choosing the Zone 3 setting. Care should be taken to grade the Zone 3 setting with the rest of the system.

As with Zone 2, the Zone 3 reach will normally be set so that it does not extend beyond a power transformer, however if a particular application requires an extension of reach beyond a transformer then the protection should be graded accordingly.

The Zone3 setting is obtained by adjustment of the impedance range.

The characteristic of the zone 3 allows for a reverse reach setting which is adjustable and this is programmed as a secondary impedance.

$$\text{Zone 3 Setting at A} \geq 1.2 \left[L_{AB} + L_{BC} \left(\frac{I_A + I_B}{I_A} \right) \right]$$

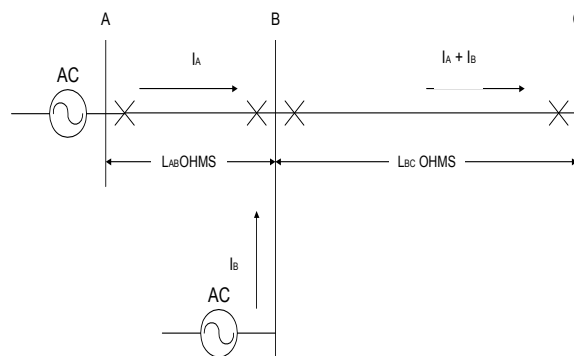

3.6 Zone 4 Setting

The Zone 4 setting has an independent impedance range the line angle is the mirror image of the forward angle and is not selectable. The Zone 4 impedance element can be used to directly trip the relay or it can be used with the scheme logic to provide reverse looking schemes.

APPENDIX A Status Inputs

As stated in the “Performance Specification”, status inputs used for protection signalling are high speed devices with operating times of under 5ms. As supplied, all status inputs are of this type.

Should the user require any status input to meet the requirements of ESI 48-4-1, i.e. to have high stability in the presence of spurious signals, the relevant status input module should be withdrawn from the relay case and the DIL switch for the desired inputs changed. “Slow” status inputs operate only once a capacitor has discharged and have an inherent pickup delay of 20ms.

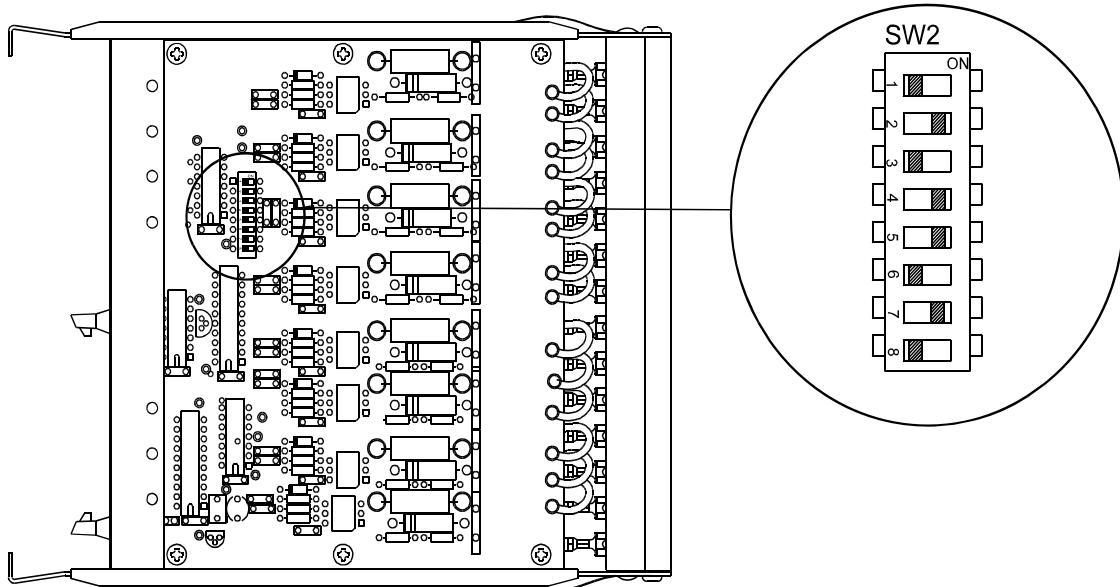

Note: Switch SW2 controls 8 status inputs. As supplied, all switches are in the left hand position and all status inputs are high speed devices.
For high stability use, the relevant switch should be moved to the right hand position as shown for switches 2, 4, 5 & 7.

7SG163 Ohmega 300 Series

7SG163 Protection Relay

Document Release History

This document is issue 2010/02. The list of revisions up to and including this issue is:
Pre release

2010/02	Document reformat due to rebrand

The copyright and other intellectual property rights in this document, and in any model or article produced from it (and including any registered or unregistered design rights) are the property of Siemens Protection Devices Limited. No part of this document shall be reproduced or modified or stored in another form, in any data retrieval system, without the permission of Siemens Protection Devices Limited, nor shall any model or article be reproduced from this document unless Siemens Protection Devices Limited consent.

While the information and guidance given in this document is believed to be correct, no liability shall be accepted for any loss or damage caused by any error or omission, whether such error or omission is the result of negligence or any other cause. Any and all such liability is disclaimed.

Contents

1	Unpacking, Storage And Handling	3
2	Recommended Mounting Position.....	3
3	Relay Dimensions	3
4	Fixings.....	3
4.1	Crimps.....	3
4.2	Panel Fixing Screws.....	3
4.3	Communications	4
5	Ancillary Equipment.....	4
6	Precautions	4

1 Unpacking, Storage And Handling

On receipt, remove the relay from the container in which it was received and inspect it for obvious damage. It is recommended that the relay modules are not removed from the case. To prevent the possible ingress of dirt, the sealed polythene bag should not be opened until the relay is to be used.

If damage has been sustained a claim should immediately be made against the carrier, also inform the local Siemens office, using the Defect Report Form in the Maintenance section of this manual.

When not required for immediate use, the relay should be returned to its original carton and stored in a clean, dry place.

The relay contains static sensitive devices, these devices are susceptible to damage due to static discharge and for this reason it is essential that the correct handling procedure is followed.

The relay's electronic circuits are protected from damage by static discharge when the relay is housed in its case. When individual modules are withdrawn from the case, static handling procedures should be observed.

- Before removing the module from its case the operator must first ensure that he is at the same potential as the relay by touching the case.
- The module must not be handled by any of the module terminals on the rear of the chassis.
- Modules must be packed for transport in an anti-static container.
- Ensure that anyone else handling the modules is at the same potential.

As there are no user serviceable parts in any module, there should be no requirement to remove any component parts.

If any component parts have been removed or tampered with, then the guarantee will be invalidated. Siemens reserve the right to charge for any subsequent repairs.

2 Recommended Mounting Position

The relay uses a liquid display (LCD) which is used in programming and or operation. The LCD has a viewing angle of $\pm 45^\circ$ and is back lit. However, the best viewing position is at eye level, and this is particularly important when using the built-in instrumentation features.

The relay should be mounted to allow the operator the best access to the relay functions.

3 Relay Dimensions

The relay is supplied in an Epsilon case 16. Diagrams are provided elsewhere in this manual.

4 Fixings

4.1 Crimps

Amp Pidg or Plasti Grip Funnel entry ring tongue

Size	AMP Ref
0.25-1.6mm ²	342103
1.0-2.6mm ²	151758

4.2 Panel Fixing Screws

2-Kits – 2995G10046 each comprising:

- Screw M4 X10
2106F14010 – 4 off

- Lock Washes
2104F70040 – 4 off
- Nut M4
2103F11040 – 4 off

4.3 Communications

Fibre optic connections – 4 per relay (Refer to section 4 – Communications Interface).

5 Ancillary Equipment

The relay can be interrogated locally or remotely by making connection to the fibre optic terminals on the rear of the relay or the RS232 port on the relay fascia. For local interrogation a portable PC is required. The PC must be capable of running Microsoft Windows Ver 3.1 or greater, and it must have a standard RS232 port. A standard data cable is required to connect from the PC to the 25 pin female D type connector on the front of the relay. For remote communications more specialised equipment is required. See the section on Communications for further information, and also see the Communications Interface manual.

6 Precautions

When running fibre optic cable, the bending radius must not be less than the cable manufacturers specifications.

If the fibre optic cables are anchored using cable ties, these ties must be hand tightened – under no circumstances should cable tie tension tools or cable tie pliers be used.

7SG163 Ohmega 300 Series

7SG163 Protection Relay

Document Release History

This document is issue 2010/02. The list of revisions up to and including this issue is:
Pre release

2010/02	Document reformat due to rebrand
3	Amended
2	Amended
1	First Issue

The copyright and other intellectual property rights in this document, and in any model or article produced from it (and including any registered or unregistered design rights) are the property of Siemens Protection Devices Limited. No part of this document shall be reproduced or modified or stored in another form, in any data retrieval system, without the permission of Siemens Protection Devices Limited, nor shall any model or article be reproduced from this document unless Siemens Protection Devices Limited consent.

While the information and guidance given in this document is believed to be correct, no liability shall be accepted for any loss or damage caused by any error or omission, whether such error or omission is the result of negligence or any other cause. Any and all such liability is disclaimed.

Contents

1	Introduction.....	3
1.1	Equipment Required	3
1.2	Inspection	3
1.3	Applying Settings	3
1.3.1	Precautions	3
1.3.2	System Parameters.....	3
2	General Tests.....	5
2.1	Status Inputs.....	5
2.2	Output Relays	5
3	Measuring Units Tests.....	7
3.1	Voltage Measurement.....	7
3.2	Current Measurement	7
4	Main Protection	8
4.1	Distance Protection.....	8
4.1.1	Impedance Reach Test.	8
4.1.2	Operating Time Test	10
4.2	Switch Onto Fault Feature.	11
4.2.1	AC SOTF	11
4.2.2	DC Line Check (Status Input control).....	11
4.3	Voltage Transformer Supervision VTS Tests.....	13
4.3.1	Residual Voltage and Current detector.	13
4.3.2	VTS blocking function.	14
4.4	Power Swing Detector Tests.....	15
4.4.1	Power Swing Impedance Reach.	15
4.4.2	Power swing transit timer.	16
4.4.3	Power swing blocking function.	16
5	Auxiliary Protection Tests.....	17
5.1	Fault Locator.....	17
5.2	High Set Overcurrent	17
5.3	Sensitive Earth Fault (SEF).	18
5.4	Overvoltage Protection.	18
5.4.1	Sensitivity Test.....	19
5.4.2	Directional Characteristic.	19
5.4.3	DEF Operating Time.	20
5.4.4	DEF Echo Send Signal - POR.....	20
5.4.5	DEF Current Reversal Guard Timer.....	20
5.5	Auto Reclose.....	21
5.5.1	Successful auto-reclosing.	21
5.5.2	Unsuccessful auto-reclosing.	22
5.6	Synchronisation Check.	23
5.6.1	Live Line and Live Bar levels.....	23
5.6.2	Angle Differential.....	23
5.6.3	Frequency Slip	23
6	End To End Testing.....	23
6.1	Distance Scheme Tests.....	24
	APPENDIX A	25

1 Introduction

The commissioning test verifies correct operation and connection of the relay within the protection scheme.

1.1 Equipment Required

Equipment Type.	Serial No.
500V Insulation Resistance Test Set.	
Two variable A.C. voltage sources with a means of varying the phase relationship between them e.g. phase shifting transformer. Ideally, a portable relay test set e.g. Doble, Omicron etc.	
Time interval meter.	
A.C. Voltmeters.	
Phase angle meter.	
D.C. supply with nominal voltage within the working range of the relay's D.C. auxiliary supply rating.	
D.C. supply with nominal voltage within the working range of the relay's D.C. status input rating.	
Continuity tester e.g. multimeter.	
<i>Additional equipment for testing the communications channel :</i> Portable PC with an electrical-to-optical RS232 converter and fibre optic connectors. A copy of Reydisp Evolution software installed on the PC to exercise the communications channel.	

1.2 Inspection

Check that the relay has not been physically damaged. Remove the relay from the case and check that the serial numbers of the relay, case and cover are all identical. Check also that the relay is the correct model and rating.

Ensure that all connections are secure and in accordance with the relay wiring diagram or the schematic diagram. Replace the relay back into the case and ensure that it is fully inserted. Ensure that the relay case is solidly bonded to a local earth point by checking the earthing connection to the case.

1.3 Applying Settings

Before applying settings to the relay, you should be familiar with the relay's menu system. Section 1 and Section 4 of the Technical Manual. The relay settings for the particular application should be applied before any secondary testing occurs. If they are not available then the relay has default settings, which can be used for pre-commissioning tests. See section 2 for a list of the relay default settings.

Settings can be entered into the relay using the keypad on the front of the relay or they can be sent to the relay, from a file, using a portable PC and Reydisp Evolution software package.

The relay features eight alternative setting groups. In applications where more than one setting group is to be used then it may be necessary to test the relay in more than one configuration.

Note : when using setting groups it is important to remember that the relay need not necessarily be operating according to the settings which are currently being displayed. There is an "active setting group" on which the relay operates and an "edit/view setting group" which allows the settings in one group to be viewed and altered while protection continues to operate on a different unaffected group. The "active setting group" and the "edit setting group" are selected in the "System Configuration Menu".

1.3.1 Precautions

Before testing commences, the relay should be isolated from the voltage transformers in line with the local site procedures. The circuit breaker closing and alarm circuits should also be isolated where practical. Ensure that the correct d.c. auxiliary voltage is applied to the circuit. See the relevant schematic diagrams for the relay connections.

1.3.2 System Parameters

Enter the system Parameters in the table below;

VT Ratio	
CT Ratio	
Positive Sequence Line Angle	
Zero Sequence Line Angle	
Positive Sequence Line Impedance	
Zero Sequence Line Impedance	

Line Length	
-------------	--

2 General Tests

2.1 Status Inputs

This test checks that the status input circuits are functioning correctly. The status input circuits should be energised in turn and observed to be operating using the instruments mode 'Status Inputs' display. A '1' indicates that the status circuit is energised, a '0' indicates that it is not.

Where practical operate the initiate condition of the status input, or failing this, connect the relevant D.C. voltage to the status input terminals to energise them:

Nominal Voltage	Operating Range
30/34	18V to 37.5V
48/54	37.5V to 60V
110/125	87.5V to 137.5V
220/250	175V to 280V

INPUT	CHECKED	NOTES
1		
2		
3		
4		
5		
6		
7		
8		
9		
10		
11		
12		
13		
14		
15		
16		
17		
18		
19		
20		
21		
22		
23		
24		
25		
26		
27		

Note: Status operating voltage need not be the same as the main energising voltage. For 110/125 volt or 220 /250 volt working, a standard status input, 48/54 volt rated will be supplied with external dropper resistor as follows:-

Nominal Voltage	Resistor Value; Wattage
110/125	2k7 \pm 5%; 2.5 W
220/250	8k2 \pm 5%; 6W

Checked
<input type="checkbox"/> OK

2.2 Output Relays

This test checks that the output relays are functioning correctly. The output relays should be energised in turn and the contacts should be checked for correct operation using a continuity tester. The output relays can be energised in a number of ways. The following is the recommended method:

Assign each output relay in turn to 'Relay Healthy' in the output relay menu. On pressing the ENTER key the output relay selected will be energised. Check with a continuity tester that the actual contacts have operated. De-

select the output relay and check that the contact returns. Consult the schematic diagram or Relay Connections Diagram in the Technical Manual for terminal numbers.

Output Relay	Type
Relay 1-3	Change Over
Relay 4+	Normally Open

OUTPUT	CHECKED	NOTES
1		
2		
3		
4		
5		
6		
7		
8		
9		
10		
11		
12		
13		
14		
15		
16		
17		
18		
19		
20		
21		
22		
23		
24		
25		
26		
27		
28		
29		

Note: when finished testing the output relays make sure that the 'Relay healthy' is re-assigned to the correct output relay given in the settings file.

Checked
<input type="checkbox"/> OK

3 Measuring Units Tests

3.1 Voltage Measurement

Apply A.C. voltage to each of the voltage input circuits of the relay using the A.C. variable voltage sources or portable relay test set. The relay should display the correct value of voltage, the value measured by the relay is displayed in the Instrument Menu; with $\pm 5\%$ accuracy. The applied A.C. volts can be in the range of 5 – 220Vrms. Nominal voltage of 63.5V or 110V is recommended.

Checked
<input type="checkbox"/> OK

3.2 Current Measurement

Apply A.C. current to each current input circuit of the relay using a variable current source. The relay should display the correct value of current, the value measured by the relay is displayed in the Instrument Menu; with $\pm 5\%$ accuracy.

Checked
<input type="checkbox"/> OK

4 Main Protection

4.1 Distance Protection

4.1.1 Impedance Reach Test.

Set the distance scheme to the stepped time scheme and programme output relays accordingly.

4.1.1.1 Earth Fault Elements Test.

Check that the minimum impedance reach of the relay, on the line angle is as per the relay setting for Earth Faults.

Line Angle = _____ °

EF Comp Z0/Z1 Ratio = _____

EF Comp Z0 Angle = _____ °

Calculated Earth Fault Compensation Factor, K_N = $\frac{1}{3} \left(\frac{Z_0}{Z_1} - 1 \right)$ = _____

If the test set incorporates automatic earth fault compensation ensure that this is configured correctly on the test set. Alternatively, if the test set has no automatic earth fault compensation then see Appendix A for details of how to measure the fault loop impedance. Record the impedance reach of each earth fault element in all zones in the table below.

Element	Relay Setting (Ω)	Fault Type	Measured Impedance (Ω)	% Error
Zone 1		A-E		
		B-E		
		C-E		
Zone 2		A-E		
		B-E		
		C-E		
Zone 3		A-E		
		B-E		
		C-E		
Zone 3 (Reverse)		A-E		
		B-E		
		C-E		

Ensure that the error does not exceed ± 5%, or ± 0.15 Ω, (whichever is larger)

Checked
<input type="checkbox"/> OK

4.1.1.2 Phase Fault Elements Test.

Check that the minimum impedance reach of the relay, on the line angle is as per the relay setting for Phase Faults.

If the test set incorporates automatic fault loop compensation, ensure that this is configured correctly on the test set. Alternatively, if the test set has no automatic fault loop compensation then see Appendix A for details of how to measure the fault loop impedance.

Element	Relay – Phase Fault Setting	Fault Type	Measured Impedance (Ω)	% Error
Zone 1		A-B		
		B-C		
		C-A		
Zone 2		A-B		
		B-C		
		C-A		
Zone 3		A-B		
		B-C		
		C-A		
Zone 3 (Reverse)		A-B		
		B-C		
		C-A		

Ensure that the error does not exceed $\pm 5\%$, or $\pm 0.15 \Omega$, (whichever is larger)

Checked
<input type="checkbox"/> OK

4.1.2 Operating Time Test

Using a test set with a constant source impedance model, and an SIR of ≤ 30 , apply phase faults and earth faults to the relay inside each of the zones of protection, on the line angle.

Check and record Zone 1, 2, 3 operating times for faults in the middle of reach zones.

Element	Time Delay Settings	Fault Type	Applied Impedance (Ω)	Measured Operating Time (ms)
Zone 1	Earth Fault = _____ ms	A-E		
		B-E		
		C-E		
	Phase Fault = _____ ms	A-B		
		B-C		
		C-A		
Zone 2	Earth Fault = _____ ms	A-E		
		B-E		
		C-E		
	Phase Fault = _____ ms	A-B		
		B-C		
		C-A		
Zone 3	Earth Fault = _____ ms	A-E		
		B-E		
		C-E		
	Phase Fault = _____ ms	A-B		
		B-C		
		C-A		

Check operating time is ≤ 50 ms for SIR ≤ 30

Checked
<input type="checkbox"/> OK

4.2 Switch Onto Fault Feature.

SOTF ENABLED DISABLED

The SOTF feature can be used in either AC or DC mode. Indicate which mode is selected below:

SOFT MODE AC SOTF Carry out tests as per Section 4.2.1
 DC SOTF Carry out tests as per Section 4.2.2

4.2.1 AC SOTF

4.2.1.1 AC SOTF Operation (Zone 3 control).

Select the pre-fault time on the test set to zero. Initiate phase-to-earth and phase-to-phase faults outside zone 1. Record the operating times and indications in the table below. Ensure that the relay indicate the correct elements and a SOTF condition.

Fault Type	Measured Operating Time (ms)	Relay Indication
A-E		<input type="checkbox"/> A-E <input type="checkbox"/> SOTF
B-E		<input type="checkbox"/> B-E <input type="checkbox"/> SOTF
C-E		<input type="checkbox"/> C-E <input type="checkbox"/> SOTF
A-B		<input type="checkbox"/> A-B <input type="checkbox"/> SOTF
B-C		<input type="checkbox"/> B-C <input type="checkbox"/> SOTF
C-A		<input type="checkbox"/> C-A <input type="checkbox"/> SOTF

4.2.1.2 AC Line Check Reset Time.

The AC line check is active for a short period after the breaker is closed.

With the pre-fault time set to 150ms, simulate a fault outside zone 1 but inside zone3.

Repeat this test with the pre-fault time set to 250ms.

Zone	Fault Type	Pre-fault time (ms)	Relay Indication
		150	<input type="checkbox"/> SOTF
		250	<input type="checkbox"/> Distance Trip

4.2.1.3 AC Line Check pick-up time.

The line must have been dead for a set time delay before the AC line check function is enabled. Using the test kit in a sequence mode, arrange the following sequence of states.

Setting of AC SOTF Pickup Delay = _____ ms

STATE 1 [1 Second]	STATE 2 [AC Line Check Time delay]	STATE 3 [Turned off when relay trips
Nominal voltage.	Zero Voltage & Current on all phases.	Current on one phase to the nominal value.

Run this sequence of state with the State 2 time set to the AC SOTF Pickup delay minus 10%.

Repeat with the state 2 time set to set to the AC SOTF Pickup delay plus 10%.

State 2 Time	Relay Operation
	<input type="checkbox"/> SOTF
	<input type="checkbox"/> NO SOTF

4.2.2 DC Line Check (Status Input control).

Select the pre-fault time to 1 second.

Ensure that the status input CB Manual Close is low, then simulate a fault within Zone 3 and outside Zone 1. Record the trip time and indication.

Energise status input CB Manual Close, then repeat the test. Ensure that the fault is initiated within 400 ms of energisation of the status input

Status Input	Fault Type	Measured Time (ms)	Operating	Relay Indication
Low	A-E			<input type="checkbox"/> A-E <input type="checkbox"/> TRIP
High	A-E			<input type="checkbox"/> A-E <input type="checkbox"/> SOTF

Ensure that with the status input low the relay trips as normal (after the relevant time delay) and with the status input high, the relay trips instantaneously with a SOTF indication.

Checked
<input type="checkbox"/> OK

4.3 Voltage Transformer Supervision VTS Tests.

VTS ENABLED DISABLED

4.3.1 Residual Voltage and Current detector.

Apply nominal voltage level on three phases and ramp down one of them until a VTS indication appears. Next, gradually increase the current on the same phase until the VTS indication drops off. Record these values in the "Measured pick-up level" column in the table below.

VTS Ires Level = _____ A

VTS Vres Level = _____ V

Calc. volts pick-up = [Vn] – [VTS Vres Level]= _____ V

Calc. Curr. Pick-up = [In]- [VTS Ires Level] = _____ A

Phase	Action	Calculated Pick-up level	Measured Pick-up level
A	Voltage to operate/reset	V	V
	Current to operate/reset	A	A
B	Voltage to operate/reset	V	V
	Current to operate/reset	A	A
C	Voltage to operate/reset	V	V
	Current to operate/reset	A	A

Ensure that the VTS picks up at the correct level.

Checked
<input type="checkbox"/> OK

4.3.2 VTS blocking function.

The dynamic performance of the VTS scheme is checked using the state sequencer of the test set to simulate various conditions as follows.

STATE 1 [1 Second]	STATE 2 [1 Second]
Nominal Current & Voltage on all three phases	Zero Voltage on 2 phases, nominal voltage on third phase. Nominal balanced 3 phase Current on all three phases.

With the VTS blocking function enabled, the relay should be stable. If, however, the VTS blocking function is disabled, the protection should trip with the corresponding indication.

VTS Mode : VTS alarm only

TRIP	<input type="checkbox"/>	OK
------	--------------------------	----

VTS Mode : VTS alarm and inhibit

NO TRIP	<input type="checkbox"/>	OK
---------	--------------------------	----

To prove the VTS blocking feature for phase faults, set up the following sequence using the test set.

STATE 1 [1 Second]	STATE 2 [1 Second]	STATE 3 [1 Second]
Nominal Current & Voltage on all three phases	Zero Volts on 2 phases Nominal PS Current on all three phases	Voltage as per State 2 Phase to phase fault current (180° phase difference)

In this case there will be no zero sequence current, although a fault has occurred. The relay will see residual voltage but no residual current and prevent tripping.

VTS Phase Fault Inhibit : Enable

NO TRIP	<input type="checkbox"/>	OK
---------	--------------------------	----

VTS Phase Fault Inhibit : Disable

TRIP	<input type="checkbox"/>	OK
------	--------------------------	----

4.4 Power Swing Detector Tests.

Power Swing Detector ENABLED DISABLED

Power swing impedance based detector consists of two mho or quad zones. The outer zone is a replica of the inner zone multiplied by a specific factor set by a user. Before starting the tests, ensure that one of the relay LEDs is mapped to the Power Swing Alarm.

4.4.1 Power Swing Impedance Reach.

Apply a balanced three-phase condition with the impedance below the impedance setting of the inner zone. Gradually increase the impedance until the Power Swing Alarm operates. Record the minimum reach of the power swing detector, i.e. the reach of the inner zone. This should be repeated for the inner reverse reach where applicable.

Inner Zone Fwd Reach = _____ Ω
 Inner Zone Rev Reach = _____ Ω

Element	Measured Impedance	% Error
Inner Zone Forward Reach		
Inner Zone Forward Reach		

Ensure that the percentage error does not exceed $\pm 5\%$

The outer reach of the Power Swing Detector zone is set by a multiplying factor. The actual outer reach is the inner reach multiplied by the PSD Outer multiplier.

PSD Outer multiplier = _____
 Outer Zone Fwd Reach = _____ Ω
 Outer Zone Rev Reach = _____ Ω

Apply a balanced three-phase condition with the impedance above the impedance setting of the outer zone. Gradually decrease the impedance until the Power Swing Alarm operates. Record the maximum reach of the power swing detector, i.e. the reach of the outer zone. This should be repeated for the outer reverse reach where applicable.

Element	Measured Impedance	% Error
Outer Zone Forward Reach		
Outer Zone Forward Reach		

Ensure that the percentage error does not exceed $\pm 5\%$

Checked
<input type="checkbox"/> OK

4.4.2 Power swing transit timer.

Apply a balanced three-phase condition with the impedance between the inner and outer power swing detector zones. Measure the minimum time that the impedance must be in the Power Swing Detector region for a Power Swing Alarm to be initiated (indicated by LED). This will give the total time (transit time plus operating time) for the Power Swing Detector.

In the table below, note the Set PSD transit time on the relay and the actual time measured for this test. In the final column, calculate the operating time for the PSD element.

Set Transit Time (ms)	Measured Time(ms)	Calculated PSD Operation Time (ms)

4.4.3 Power swing blocking function.

In the table below tick the zones of protection that are blocked when a power swing occurs, and those which are not blocked.

Using the State sequencer, set up two states.

STATE 1. System impedance between the inner and outer zones of the Power Swing Detector.

STATE 2. System impedance within Zone 3.

This is repeated, altering state 2 to bring the impedance within Zone 1 and 2. Check that in zones which are blocked, the protection doesn't operate, and those which are not blocked the protection does operate.

	Unblocked	Blocked	Checked
Zone 1	<input type="checkbox"/>	<input type="checkbox"/>	<input type="checkbox"/>
Zone 2	<input type="checkbox"/>	<input type="checkbox"/>	<input type="checkbox"/>
Zone 3	<input type="checkbox"/>	<input type="checkbox"/>	<input type="checkbox"/>

5 Auxiliary Protection Tests

5.1 Fault Locator

Enter Line Parameters in the table below;

Line Length, L = _____ m
 Line Impedance, Z_L = _____ Ω
 Line Angle, θ = _____ $^\circ$

The fault locator can be set to display location as percentage or distance. Apply two different type of fault at 50% of the total line impedance, and a further two faults at 100% of the total line impedance.

Fault Location	Fault Type	Expected Reading	Actual Reading	Error (%)
50 %				
50%				
100%				
100%				

Ensure that the error is less than $\pm 5\%$ in each case.

Checked
<input type="checkbox"/> OK

5.2 High Set Overcurrent

HSOC ENABLED DISABLED

The high set overcurrent element will pick-up independantly of the distance protection elements, when it detects a current above it's setting. Using the test set simulate a fault in zone with fault current lower than the HSOC setting. Repeat this gradually increasing the fault current until the HSOC detector picks up. Record the relay settings, the calculated pick-up level and the minimum operating level of the high set overcurrent relay below.

Nominal Current = _____ A
 High Set = _____ x I_n

Calculated Pick-up[A]	Measured Pick-up[A]	Relay Operation	
		<input type="checkbox"/> Trip	<input type="checkbox"/> HSOC

5.3 Sensitive Earth Fault (SEF).

SEF ENABLED DISABLED

Apply sensitive earth fault condition and measure the pick-up level of the SEF element.

SEF Pick-up		
Setting	Measured	Indication
		<input type="checkbox"/> SEF

Apply SEF conditions at double the setting current ($2 \times I_s$). Measure time between Application of SEF conditions and the SEF alarm operation, and the SEF trip operation.

Applied SEF (A)	SEF Alarm		SEF Trip	
	Setting	Measured	Setting	Measured

5.4 Overvoltage Protection.

OVERVOLTAGE PROT ENABLED DISABLED

There are two stages of overvoltage definite time delay protection, referred to as Alarm and Trip. Record operating values for each of them.

Overvoltage Alarm Level = V
 Overvoltage Alarm Time = ms
 Overvoltage Trip Level = V
 Overvoltage Trip Time = ms

Phase	Alarm		Trip	
	Level	Time	Level	Time
A				
B				
C				

Directional Earth Fault

DEF ENABLED DISABLED

The directional earth fault responds to residual current and voltage. The magnitude of the residual voltage is not important, as the relay only requires a minimal voltage level for its polarising signal – it can be set to a value of 10% of V_n for these tests. The phase angle referred to in these tests is the angle between residual current and voltage.

5.4.1 Sensitivity Test.

Set DEF into “Direct Trip” mode. Apply a balanced three-phase set of current and voltage to the relay. On top of this apply a residual voltage at 10% of V_n . Increase the residual current at the characteristic angle until DEF operates. Measure the operating threshold level.

Earth Fault Current		Relay Operation
Setting [A]	Measured[A]	
		<input type="checkbox"/> DEF

5.4.2 Directional Characteristic.

Set DEF into “Direct Trip” mode. Set directional characteristic into forward direction. Apply residual current at 2x setting and residual voltage at 10% of V_n to the relay at the angles shown in the table below. Confirm that the directional characteristic operates at the relay characteristic angle $\pm 85^\circ$.

Applied residual current = _____ A

Applied residual voltage = _____ V

Phase Angle	Operation
+90°	<input type="checkbox"/> Stable
+80°	<input type="checkbox"/> DEF
0°	<input type="checkbox"/> DEF
-80°	<input type="checkbox"/> DEF
-90°	<input type="checkbox"/> Stable

5.4.3 DEF Operating Time.

Set the relay DEF mode back to DEF POR.

The DEF can operate in one of two ways;

Aided trip occurs when the local relay detects a DEF and receives a permissive signal from the remote end to indicate that the remote end relay has also detected a DEF condition – this causes a permissive trip.

Back-up trip occurs when a DEF condition is detected and remains on the system for longer than the DEF backup trip time.

Ensure that the Signal Receive 2 status input is low. Apply DEF conditions at one end only and measure the time taken for a back-up DEF trip. Next, energise the Signal Receive 2 status input. Repeat the test and measure the time taken for a permissive DEF trip. Record both times in the table below.

Sig Receive 2 Status Input	Nominal Time [ms]	Actual Time [ms]	Indication
High			<input type="checkbox"/> DEF Aided Trip
Low			<input type="checkbox"/> DEF

5.4.4 DEF Echo Send Signal - POR.

If the local circuit breaker is open when a permissive signal is received, the relay will “Echo” a permissive trip signal back to the remote end. Make sure that the status input for DEF CB Close is low. Energise the Signal Receive 2 input and measure the time for which Signal Send 2 is high.

DEF Echo Pulse Width Time (ms)	Measured time (ms)	Operation
		<input type="checkbox"/> Signal Send 2

5.4.5 DEF Current Reversal Guard Timer.

Set the test kit into a sequence mode. Energise “Signal Receive 2” and “CB DEF Close” status inputs. Two states are required.

STATE 1 Directional Earth Fault in the reverse direction

STATE 2 DEF in the forward direction and the current reversal reset time to the required value.

During state 2 the relay will trip after DEF Current Reversal Reset time.

DEF Current Reversal Reset (ms)	Measured time (ms)	Operation
		<input type="checkbox"/> DEF Aided Trip

5.5 Auto Reclose.

The relay incorporates an embedded three phase, single shot auto-reclosing feature which can be activated in "Auto-reclosing" menu. In order to test this feature, the test equipment must be arranged to run through a sequence of states to simulate the sequence of events which occur during an auto-reclose sequence.

The status of the auto-reclose sequence can be viewed in "Instruments" mode under "auto-reclose state" [it may be necessary to temporarily disable to fault locator to view all indications in this mode]. During a successful auto-reclosing sequence, the sequence of messages is as follows:

```

"IDLE"
"THREEPOLEDEADTIME"
"CBCLOSEPULSE"
"RECLAIM"
"IDLE"

```

5.5.1 Successful auto-reclosing.

Disable the synchronisation feature by selecting "Dead Line and Dead Bar" to "Enable" position. Then, switch "Auto-reclose" from "Out" to "In" position.

Arrange the test kit to run through the following states

STATE 1 [1 s].

Nominal Current, Nominal Voltage, Breaker Closed.

STATE 2 [100ms].

Single Phase Zone 1 fault, Breaker Closed.

STATE 3 [Until close pulse is issued].

Current zero, Voltage zero, Breaker open.

STATE 4 [1s].

Nominal Current, Nominal Voltage, Breaker Closed.

This sequence of events should initiate a successful auto-reclose sequence. Monitor the sequence of events and record auto-reclosing operating times from the relay interface -Reydisp.

AR Function	Measurement	Nominal Time[ms]	Actual Time[ms]
Dead Time	State 3 Time		
CB Close Pulse	CB Close Pulse Width		
Reclaim Time	From : A/R CB Close Pulse Reset To : A/R In Progress Reset		

5.5.2 Unsuccessful auto-reclosing.

The following are conditions under which auto-reclosing will not be successfully executed. Check for correct operation of the relay in each case.

Fault/Plant Condition	Relay Operation
Zone 2,3,4, trip	<input type="checkbox"/> No Auto Reclose
Blocking A/R status input high	<input type="checkbox"/> No Auto Reclose
3 Phase Fault	<input type="checkbox"/> Auto Reclose Lockout
Failure in opening a circuit breaker	<input type="checkbox"/> Auto Reclose Lockout
Failure in re-closing a circuit breaker	<input type="checkbox"/> Auto Reclose Lockout
Go direct into lock-out status input	<input type="checkbox"/> Auto Reclose Lockout

5.6 Synchronisation Check.

The check synchronisation feature is only used by the relay during synchronised auto reclosing, but it runs continuously. Thus the pick-up and drop-off levels can be measured easily. Set up the test set to apply voltages to the yellow phase line VT input and the synchronising VT input. Assign LEDs to Live Bar, Live Line and In Sync.

5.6.1 Live Line and Live Bar levels.

Note the relay settings below.

Bus Live	=	%
Bus Dead	=	%
Line Live	=	%
Line Dead	=	%

Start with the line voltage above the live line setting. Reduce the line voltage until the Live line LED goes out – this is the Measured dead line level setting. Then gradually increase this voltage until the LED lights again. This is the measured live line level – record this in the table below.

Plant	Measured Voltage		Percentage Voltage	
	Live [V]	Dead [V]	Live [V]	Dead [V]
Bus				
Line				

5.6.2 Angle Differential

Start the test with busbar voltage and line voltage at the same angle. Gradually increase the angle between them in the positive direction until the LED assigned to In Sync drops off. Repeat this test in the opposite direction. Record positive and negative phase angle differences in the table below.

Parameters	Relay Setting	Positive angle	Negative angle
Sync-Check	±	°	°
System Check	±	°	°

5.6.3 Frequency Slip

Start the test with busbar voltage and line voltage at the same angle, but a frequency differential greater than the relay Check Sync slip between them. This will cause the busbar voltage and the line voltage to slip relative to one another. Using the instruments mode bring up the Check Sync Line/Bus Phase Diff. Wait to see if the In Sync LED comes on when the voltages come into synchronism. If not gradually reduce the frequency difference until the LED assigned to In Sync comes on when the voltages are synchronised.

Parameters	Relay Setting	Positive Frequency Slip	Negative Frequency Slip
Sync-Check	±	°	°
System Check	±	°	°

6 End To End Testing

In cases where signalling is used in a distance protection scheme, end-to-end testing should be carried out in order to ensure that the relay and the signalling channel are working correctly.

The main difficulty presented by this type of test is the synchronisation between test equipment at the local and remote ends. It is not recommended to attempt to simulate faults at both ends of the line without identical test sets and some sort of synchronising system between them. Since such a test is difficult to set up, the recommended method of end-to-end testing is as follows.

6.1 Distance Scheme Tests.

Ensure that the signal received 1 output is mapped to an LED. With the signalling channel in service, initiate a zone 1 fault and check that the permissive signal is received at the remote end. This is indicated by operation of the assigned LED on the remote end relay.

Checked
<input type="checkbox"/> OK

Next, manually energise the signal send 1 signalling channel from the remote end. Simulate a zone 2 fault at the local end and ensure that the operating time of the local end relay is less than the zone 2 operating time, indicating that acceleration of the zone 2 element has occurred.

Fault	Status Inputs	Expected Response	Relay Operation
Zone 2	Remote end signal send 1 high.	Relay trips Zone 1	<input type="checkbox"/> OK
		Relay Autorecloses	<input type="checkbox"/> OK
		Signal sent – Channel 1	<input type="checkbox"/> OK

APPENDIX A**A.1 Fault Loop Compensation For Earth Faults**

The relay is set in terms of positive sequence impedance. To calculate the actual fault loop impedance follow the steps below. Start by recording the relay settings;

Line Angle = _____

EF Comp Z0/Z1 Ratio = _____

EF Comp Z0 Angle = _____

Calculated Earth Fault Compensation Factor, $K_N = \frac{1}{3} \left(\frac{Z_0}{Z_1} - 1 \right) =$ _____

Then calculate voltage, current and actual impedance using the formulae:

$$V = IZ_1 (1 + K_N)$$

Where Z1 is the positive sequence impedance (i.e. the relay setting)

Zone 1

Phase	Effective Impedance	Total Loop Impedance	Current Injected	Phase Angle	Voltage Injected	Phase Angle
A						
B						
C						

Zone 2

Phase	Effective Impedance	Total Loop Impedance	Current Injected	Phase Angle	Voltage Injected	Phase Angle
A						
B						
C						

Zone 3 (Fwd)

Phase	Effective Impedance	Total Loop Impedance	Current Injected	Phase Angle	Voltage Injected	Phase Angle
A						
B						
C						

Zone 3 (Rev)

Phase	Effective Impedance	Total Loop Impedance	Current Injected	Phase Angle	Voltage Injected	Phase Angle
A						
B						
C						

A.2 Fault Loop Compensation For Phase Faults

The relay is set in terms of positive sequence impedance. To calculate the actual fault loop impedance follow the steps below.

Calculate voltage from the formulae:

$$V = 2IZ_1$$

Where Z1 is the positive sequence impedance (i.e. the relay setting)

Zone 1

Phase	Effective Impedance	Total Loop Impedance	Current Injected	Phase Angle	Voltage Injected	Phase Angle
A						
B						
C						

Zone 2

Phase	Effective Impedance	Total Loop Impedance	Current Injected	Phase Angle	Voltage Injected	Phase Angle
A						
B						
C						

Zone 3 (Fwd)

Phase	Effective Impedance	Total Loop Impedance	Current Injected	Phase Angle	Voltage Injected	Phase Angle
A						
B						
C						

Zone 3 (Rev)

Phase	Effective Impedance	Total Loop Impedance	Current Injected	Phase Angle	Voltage Injected	Phase Angle
A						
B						
C						

7SG163 Ohmega 300 Series

7SG163 Protection Relay

Document Release History

This document is issue 2010/02. The list of revisions up to and including this issue is:

Pre release

2010/02	Document reformat due to rebrand
3	Amended
2	Amended
1	First Issue

The copyright and other intellectual property rights in this document, and in any model or article produced from it (and including any registered or unregistered design rights) are the property of Siemens Protection Devices Limited. No part of this document shall be reproduced or modified or stored in another form, in any data retrieval system, without the permission of Siemens Protection Devices Limited, nor shall any model or article be reproduced from this document unless Siemens Protection Devices Limited consent.

While the information and guidance given in this document is believed to be correct, no liability shall be accepted for any loss or damage caused by any error or omission, whether such error or omission is the result of negligence or any other cause. Any and all such liability is disclaimed.

Contents

- 1 Maintenance Instructions 3
- 2 Troubleshooting Guide 4
- 3 Defect Report Form..... 6

1 Maintenance Instructions

The relay is a maintenance free device, with no user serviceable parts. During the life of the relay it should be checked for operation during the normal maintenance period for the site on which the product is installed. It is recommended the following tests are carried out:

- 1 Visual inspection of the metering display (every year)
- 2 Operation of output contacts (every 2 years)
- 3 Secondary injection of each element (every 5 years)

2 Troubleshooting Guide

The following table describes the action of the relay under various conditions, and suggested remedial actions when problems are encountered.

If problems are being experienced and the suggested action does not work, or the problem is not detailed below, then please contact Siemens.

SYMPTOM	PROBLEM	ACTION
LCD Screen is faint or difficult to read.	Contrast too low	Press TEST/RESET & UP Button simultaneously
LCD Screen is dark or has lines across it.	Contrast too high	Press TEST/RESET & DOWN Button simultaneously
Protection Healthy LED not lit, LCD blank, Backlight off & No Flag LEDS lit.	Relay is not powered up	Check Auxiliary DC supply is available. Check connections on rear of relay.
Relay LCD displays "PSU alarm asserted, supply out of limits"	Power supply is too low.	Check the magnitude of the input DC voltage. Ensure it is within the relay's working range of 37.5 to 137.5 V
	Internal ribbon cable connection not made.	Check ribbon connection cable to module A is correctly attached.
Protection Healthy LED blinking, Messages & cursor blocks flashing across the LCD screen	Internal ribbon connections not made correctly	Check ribbon connection cables to each module are correctly attached.
Relay displays "Number of inputs or outputs changed... Relay must cold start... Settings will be defaulted...Please press enter"	Relay has performed a cold start due to a perceived change in hardware.	If the hardware has not been changed (i.e. status input/relay output card added or removed) then there may be a problem with the hardware. Contact Siemens
Protection Healthy LED is flashing. Protection Healthy Output contact is not energised.	Watchdog Operated: Hardware or Software Fault	Contact Siemens
Protection Healthy LED is steady, and LCD screen displays ohmega symbols (Ω). Protection Healthy Output contact is not energised.		

SYMPTOM	PROBLEM	ACTION
Relay unable to communicate using ReyDisp Evolution software	Communication channel incorrectly configured. Refer to Section 6 of this manual for more details on the configuration of the Communication Channel	Ensure connection between PC and relay (either via the front RS232 port or TX2 and RX2 on the rear of the relay) has been correctly made.
		Ensure Relay address is set correctly on both the relay and within ReyDisp Evolution. If the relay address is set to "0" the relay will not communicate.
		Ensure the baud rate / parity settings on the PC are the same as those set on the relay.
		If using the front port ensure that the setting <i>IEC870 on Port</i> is set to COM2 & COM2 DIRECTION is set to either Auto-Detect or the port being used.

7SG163 Ohmega 300 Series

7SG163 Protection Relay

Document Release History

This document is issue 2010/02. The list of revisions up to and including this issue is:
Pre release

2010/02	Document reformat due to rebrand

The copyright and other intellectual property rights in this document, and in any model or article produced from it (and including any registered or unregistered design rights) are the property of Siemens Protection Devices Limited. No part of this document shall be reproduced or modified or stored in another form, in any data retrieval system, without the permission of Siemens Protection Devices Limited, nor shall any model or article be reproduced from this document unless Siemens Protection Devices Limited consent.

While the information and guidance given in this document is believed to be correct, no liability shall be accepted for any loss or damage caused by any error or omission, whether such error or omission is the result of negligence or any other cause. Any and all such liability is disclaimed.

Contents

- Figure 1 Relay Connections
- Figure 2 Overall dimensions and panel drilling for Epsilon E16 Case

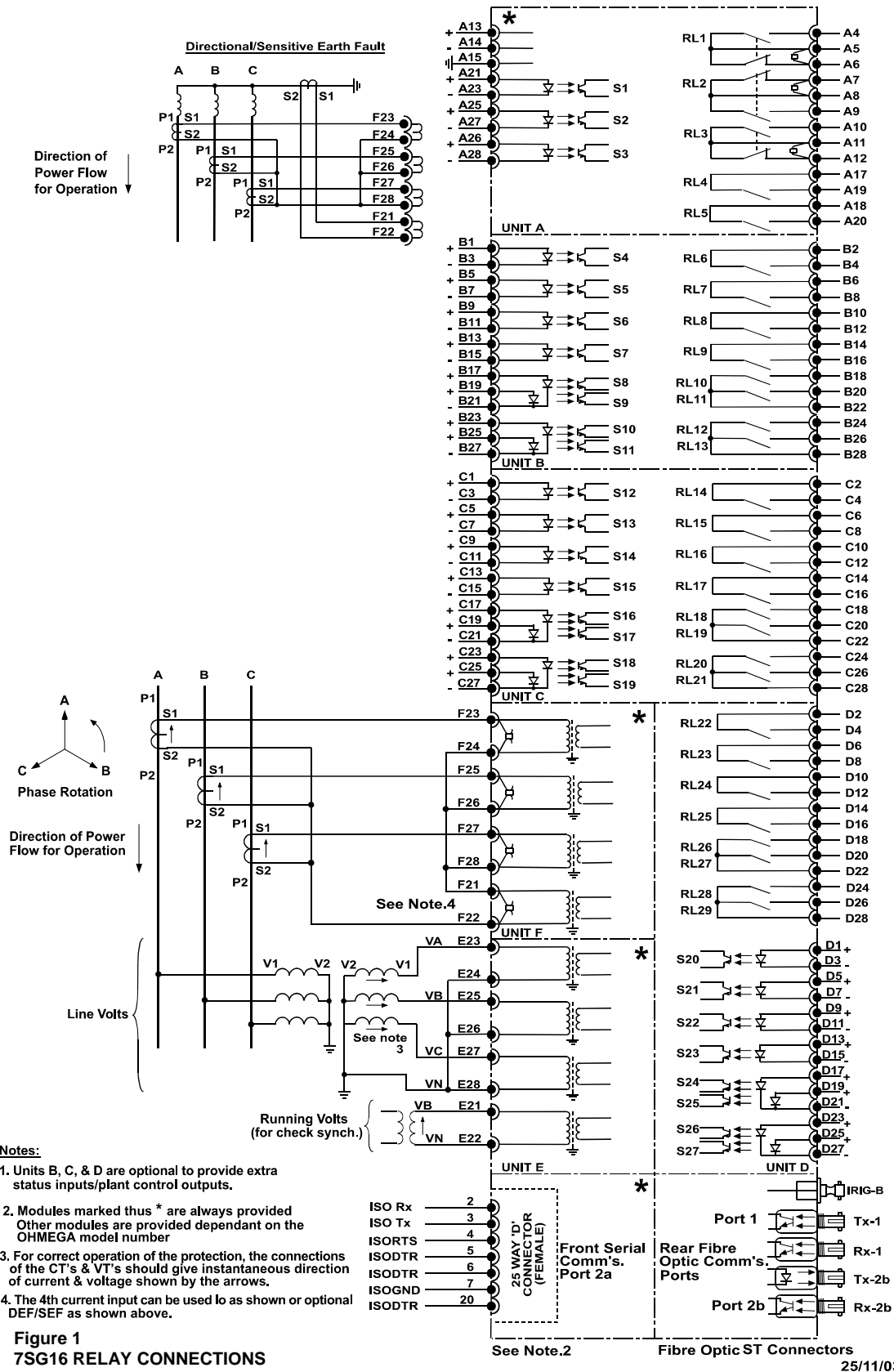

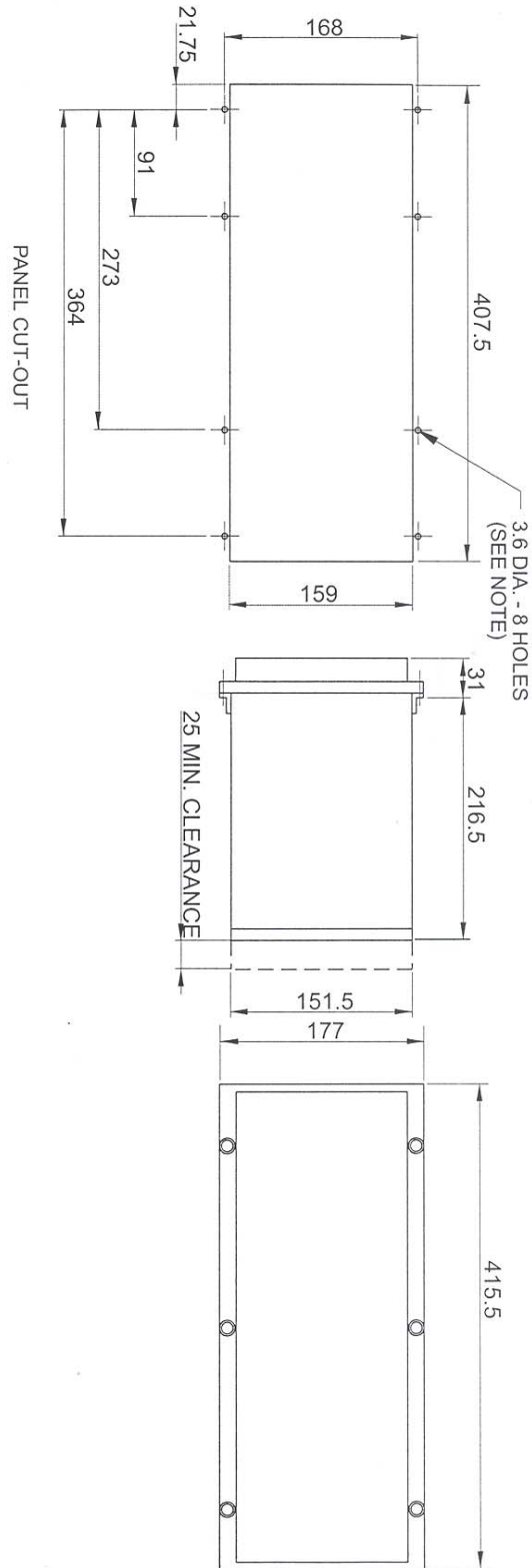

NOTE:
 THE 3.6 DIA. HOLES ARE FOR M4 THREAD FORMING (TRILOBULAR) SCREWS. THESE ARE SUPPLIED AS STANDARD AND ARE SUITABLE FOR USE IN FERROUS/ALUMINIUM PANELS 1.6mm THICK AND ABOVE. FOR OTHER PANELS, HOLES TO BE M4 CLEARANCE (TYPICALLY 4.5 DIA.) AND RELAYS MOUNTED M4 MACHINE SCREWS, NUTS AND LOCKWASHERS (SUPPLIED IN PANEL FIXING KIT).

figure 2
 OVERALL DIMENSIONS AND PANEL DRILLING FOR EPSILON E16 CASE

24/8/99

7SG163 Ohmega 300 Series

7SG163 Protection Relay

Document Release History

This document is issue 2010/02. The list of revisions up to and including this issue is:
Pre release

2010/02	Document reformat due to rebrand

The copyright and other intellectual property rights in this document, and in any model or article produced from it (and including any registered or unregistered design rights) are the property of Siemens Protection Devices Limited. No part of this document shall be reproduced or modified or stored in another form, in any data retrieval system, without the permission of Siemens Protection Devices Limited, nor shall any model or article be reproduced from this document unless Siemens Protection Devices Limited consent.

While the information and guidance given in this document is believed to be correct, no liability shall be accepted for any loss or damage caused by any error or omission, whether such error or omission is the result of negligence or any other cause. Any and all such liability is disclaimed.

Contents

1	Introduction	3
1.1	Auto-reclose	3
1.2	Check Synchronisation	3
2	Description of Operation	4
2.1	Analogue Inputs	4
2.2	Status Inputs	4
2.3	Relay Outputs	4
2.4	Auto-reclose Sequence	4
2.5	Synchronising Conditions	6
2.6	Metering	10
3	Performance Specification	11
3.1	Accuracy	11
3.2	Accuracy General	11
3.3	Accuracy Influencing Factors	11

1 Introduction

1.1 Auto-reclose

Auto-reclose is commonly applied to Transmission and Distribution systems. Statistically, the majority of system faults are of a transient nature so that once the fault has been cleared by the protection, the faulted circuit can be re-energised with a likelihood of minimal disturbance to the rest of the system. An important feature of overhead line faults is that since air is the main insulant a significant majority of flash-overs cause no permanent damage to the circuits and about 88% of fault clearances can be quickly followed by the circuits return to service by operation of automatic switching and reclosing facilities.

The single-shot auto-reclose sequence provided is shown in the diagram below;

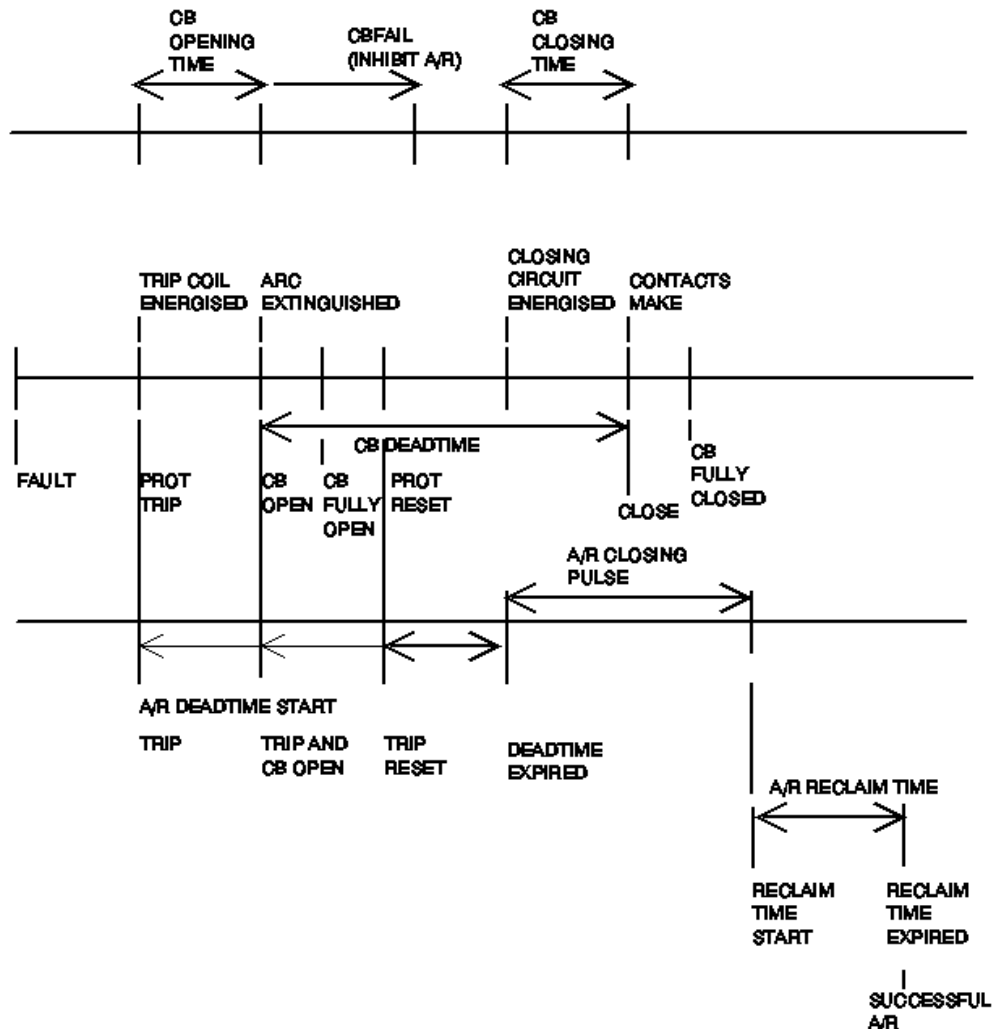

Figure 1 – Auto-reclose Sequence

1.2 Check Synchronisation

When two power systems are to be connected together it is essential that the systems either side of the breaker be reasonably in synchronism. Quantities such as the voltage magnitudes, the system frequencies and the relative phase angles of the two systems are acceptable before an attempt is made to connect. Closing the circuit breaker without due care and attention to some or all of these quantities can cause undue stresses to the system. The Check and System synchronising function measures single phase voltage quantities at each side of the CB and will only permit a CB close when the two systems fall within the relay setting parameters.

2 Description of Operation

2.1 Analogue Inputs

The relay compares the voltage on either side of the breaker. The line side voltage is taken from the phase B voltage input. On the busbar side, the reference voltage is taken from the busbar VT, and may be connected either between the B phase and earth or between phase A and phase B. This busbar voltage is applied to inputs E21 and E22.

2.2 Status Inputs

The Ohmega relay can be supplied with up to 27 user configurable Status inputs. Any of these inputs can be assigned to one or more standard functions. These functions include circuit breaker status, Autorecloser in and out of service, external triggering, blocking and lockout functions.

2.3 Relay Outputs

The Ohmega relay can be supplied with up to 29 user configurable Outputs. Any of these output contacts can be assigned to one or more standard functions. These functions include circuit breaker close pulse, circuit breaker position, AR in/out of service and circuit breaker failure.

2.4 Auto-reclose Sequence

The relay incorporates a number of safeguards to prevent mal-operation of the auto-reclose system. The relay tends to err on the side of not closing, since the operational consequences of a failure to reclose are generally less onerous, than those for an unwanted reclosure.

The status of the Auto-reclose sequence can be monitored in the Instruments Menu, using the Auto-reclose State Instrument

2.4.1 In/Out Switching

The auto-reclose in/out of service switching is controlled using two status inputs defined as AR IN and AR OUT. The A/R feature may be switched out of service in one of two ways. Either via the HMI (from the front panel or via a pc over a communication link) or by an A/R OUT status input. A/R OUT status input has priority over A/R IN. If both are raised the relay will be in Out Of Service. Once the relay has been switched Out Of Service the reverse action A/R IN is required before the relay will go back In Service. The A/R In Status Input is positive edge triggered. Initially, with the autorecloser in service, but not started, the autoreclose state instrument will display IDLE.

2.4.2 CB in Service/CB Memory

This is used with the Live Line Check functionality. If the Line voltage was "dead" for 2 seconds prior to tripping – CB maintenance condition - the ARC functionality is disabled. This prevents auto-reclosing when the line is normally de-energised or normally open.

2.4.3 Auto-reclose Initiation

If the CB is in service and the Autorecloser is in service, the Auto-reclose system will be initiated by:

- 1P or 2P Zone 1 earth or phase fault
- A 1P or 2P carrier aided trip
- Energisation of the Trip and Reclose status input.

The autoreclose can be set to start for the following additional fault types:

- 3P Zone 1 trip
- 3P carrier aided trip
- Zone 2
- Zone 3
- Directional Earth Fault
- Directional Earth Fault carrier aided trip

The Autoreclose will not start for any trip when the Block Auto-reclose status input is energised. Under these conditions, the autorecloser will remain in IDLE mode. It will not go to lockout, but no Auto-reclose operation will be started.

The relay will go direct to Lockout if the following faults occur:

- Switch-On-To-Fault.

2.4.4 Dead Time.

Once the cycle has been initiated, the relay will check that the protection and the circuit breaker have operated correctly, before the dead time delay starts. The relay uses three criteria to check this;

- The circuit breaker has opened (status taken from CB Auxiliary contacts)
- Trip initiation has been removed
- Line voltage has gone to zero (Live Line check).

Where VT on the line side of the circuit breaker are not available, the live line check should be disabled. A timer called the Sequence Fail Timer supervises this process. If the relay does not see all these events occur between the trip initiation and the end of the Sequence Fail Timer, the relay will Lockout.

Once the dead time has been successfully started, the relay will wait for the dead time to expire. If, during the dead time, the relay detects that the CB has closed (due to an external source) it increments its reclose count and advances to the next part of the reclose sequence (begin reclaim time).

2.4.5 Closing Conditions.

Once the dead time has expired, the relay will check the closing conditions, which may be set as a combination of the following options;

- Dead Bar Charge – Busbar voltage is “dead” with Line “live”
- Dead Line Charge – Line voltage is “dead” with Bus “live”
- Dead Line & Dead Bar Close – Both line and bus are “dead”
- Check Sync Close – Both line and bus are “live”
- Unconditional Close – Close regardless of bus and line voltage.

The checking of these conditions will take approximately 2 seconds. A timer known as the Sync Close Delay is started at the end of the dead time. If the synchronising conditions are not met within this time, the relay will go to lockout. For more detail on the synchronising system see part 2.5 of this section.

The Auto-reclose State Instrument will indicate CLOSE INHIBIT while the relay checks the close conditions are being evaluated.

If the specified conditions are met within the sync close delay, the relay will issue a close pulse. The Auto-reclose State instrument will indicate CLOSE PULSE. This contact will remain closed for the duration of the CB Close Pulse width. If the CB has not closed by the end of this time delay, the relay will go to lockout, and operate the CB Fail to Close alarm. If the relay trips during the close pulse the relay will lockout and operate the Close onto Fault output.

2.4.6 Reclaim Time.

After the close pulse has been issued, the reclaim time is started. The Auto-reclose state instrument will indicate RECLAIM TIME. After the breaker recloses once of two things will occur. Either the reclose will be successful and the fault will be removed from the system, or it will fail and the relay will trip and lockout the auto-recloser

If the auto-reclose cycle is successful, and the transient fault has been removed, the relay will reset the Auto-reclose cycle at the end of the reclaim time. The Auto-reclose state instrument will return to IDLE.

2.4.7 Block Auto-reclose.

Energisation of the block Auto-reclose status input will pause the Auto-reclose sequence. All timers currently active will be paused until the input is de-energised. Another timer, defined as the reclose blocked delay will start when this status input is energised, and if it remains energised for longer than this delay, the relay will go into lockout.

Note that block Auto-reclose and Auto-reclose lockout are not the same thing. A block is applied for a condition in which it may not be safe to reclose at that time, but the situation may recover.

2.4.8 Auto-reclose Lockout.

The Lockout state can be reached for a number of reasons as described in the preceding sections. Once the Lockout condition has been reached, it will be maintained until reset. Lockout will normally be reset when the circuit breaker is successfully closed. Alternatively, if required it can be reset after a time delay (by enabling Reset Lockout by timer in the Auto-reclose menu) or via the Reset Lockout status input (provided there is no signal present which will cause Lockout).

The Lockout condition has a delayed drop-off of 2s. Lockout does not issue a trip signal.

Lockout indicates an abnormal system occurrence, an event that needs to be investigated. When a CB is normally open the A/R relay does not go to Lockout, but A/R sequences are prevented by using a combination of Trip and CB In Service to start the sequence.

2.5 Synchronising Conditions

The Check and System Synchronising function measures single phase voltage quantities on each side of the CB and will only permit a CB close when the two systems fall within predefined limits. The following section describes the various criteria used to determine whether or not to issue a close pulse to the breaker, during an auto-reclose or a manual close operation. Those criteria are summarised in the diagram below;

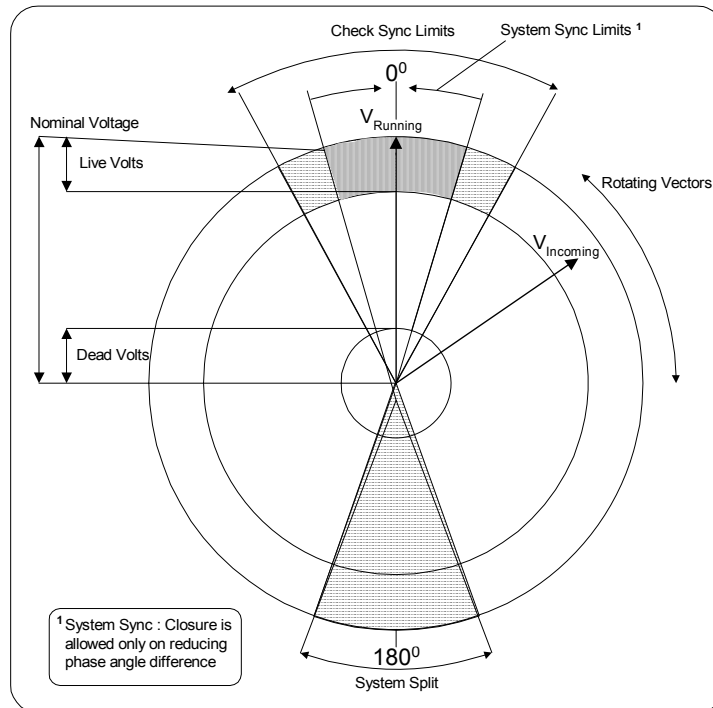

Figure 2 - Check and System Synchronising

2.5.1 Phase angle and frequency monitoring elements

The relay will monitor the angle between the line and busbar voltages, as long as those voltage are greater than 5V. The relay has two synchronising modes, System Sync and Check Sync. When the synchronism is being evaluated, if the angle between bus and line voltage is less than the Split Angle, the relay will use the Check Sync settings. If this angle increases above the Split Angle setting, the relay will use the System Sync settings, and will only allow a close if the phase angle between the two signals is decreasing.

2.5.2 Voltage monitoring elements

2.5.2.1 Undervoltage detectors

The undervoltage detectors, if enabled, can block a close output command if either the line voltage or the bus voltage is below the undervoltage setting value. Both line and bus have their own independent settings.

2.5.2.2 Differential voltage detectors

The differential voltage detector, if enabled, can block a close output command if the difference between the line and bus voltages is greater than the differential voltage setting value.

2.5.2.3 Voltage detectors

Voltage detectors determine the status of the line or bus. If the voltages on either the line or bus are below a set threshold level they can be considered to be 'dead'. If the voltages are within a setting band around the nominal voltage they are classed as 'live'. Independent voltage detectors are provided for both line and bus.

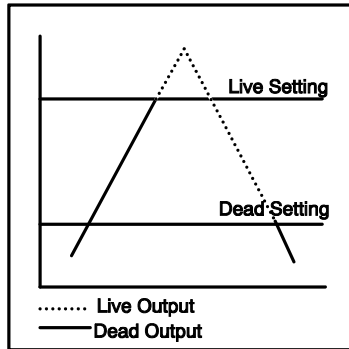

If a voltage is in the dead band range then it will be classed as dead until it has reached the live band area. Similarly, if a voltage is live, it continues to be live until it has reached the dead band area. This effectively allows for variable amounts of hysteresis to be set. Figure 3 illustrates the voltage detector operation.

Note : the area between the dead and live zones is not indeterminate. When any voltage is applied to the relay it will ramp up the software RMS algorithm and always pass through the dead zone first.

Figure 3 – Voltage Detector Operation

Although a wide range is provided for live and dead voltage detector levels, these must not overlap. The relay software acts to prevent this from happening and this is to stop unusual alarm outputs and conflicts with internal logic elements. If the user attempts to increment the dead voltage level to the live voltage level, the relay will not accept the setting. Similarly, if the live level decrements to the dead level, the setting will not be allowed. The two voltages are displayed simultaneously on the LCD display so that this operation is clear to the user.

2.5.3 Sync Override Feature

For certain switching operations, a means of bypassing the Check Synchronisation function is provided, via two status inputs. This is provided with a separate Sync Override and a separate Manual Sync Override.

2.5.4 Check Synchronising Mode

For the relay to issue a CheckSync Close the following conditions have to be met :

CHECK SYNC ANGLE – the phase difference between the line and bus voltages has to be less than the phase angle setting value. Whilst within the limits the phase angle can be increasing or decreasing and the element will still issue a valid close signal.

CHECK SYNC SLIP – the frequency difference between line and bus has to be less than the slip frequency setting value.

CHECK SYNC TIMER – the phase angle and voltage blocking features have to be within their parameters for the length of the slip timer setting. If either the phase angle or the voltage elements fall outside of their limits the slip timer is reset. If they subsequently come back in then the slip timer has to time out before an output is given. (This ensures that a close output will not be given if there is a transient disturbance on the system due to e.g. some remote switching operations).

LINE U/V DETECTOR – the line voltage has to be above the line undervoltage setting value and also above 5V for an output to be given.

BUS U/V DETECTOR – the bus voltage has to be above the bus undervoltage setting value and also above 5V for an output to be given.

DIFFERENTIAL VOLTAGE DETECTOR – the difference between the line and bus voltages has to be less than the ΔV detector setting value for an output to be given.

The relay is always started in Check Synchronising mode of operation. To proceed to System Synchronisation a system split must occur.

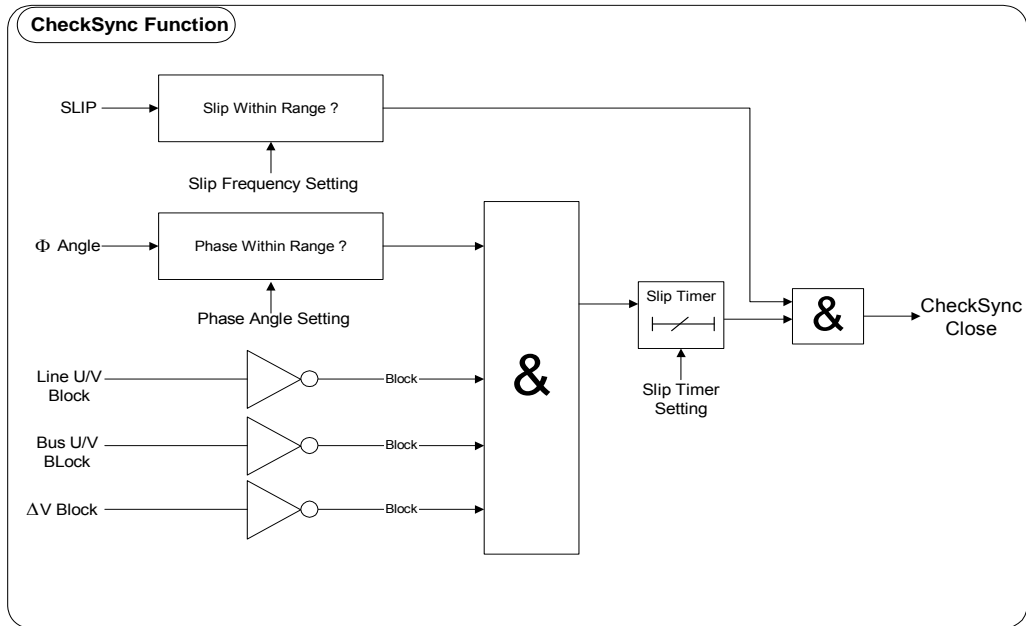

Figure 4 - Check Sync Function

2.5.5 Manual Sync Override Feature

If manual closes are required to be carried out via an operator, these will be performed with Check Synchronisation unless the Manual Sync Override input is energised.

2.5.6 System Split Detector

A system split occurs where there is a loosely tied or non-parallel circuits on a power system. Under these conditions the frequencies of the voltages either side of the breaker are asynchronous and therefore high phase angle differences can occur as the frequencies slip past each other. The system split detector operates when the phase angle difference exceeds a pre-set value. The setting range for a system split is from 90°-175° step 1°.

Note : the system split setting is effectively an absolute value and therefore a split will occur at the value regardless of the direction of the frequency slip e.g. if an angle of 170° is selected, then starting from 0°, a split will occur at +170° or -170° (effectively +190°).

If a system split occurs during a CheckSync operation the following events occur :

- The CheckSync function is inhibited.
- The SystemSync function is started if the setting has been set to A/R Split Action SYSTEM SYNC. If the A/R Split Action has been set to LOCKOUT, then, a system split LED indication is given. The relay will stay in this lockout mode until one of the following methods of resetting it is performed:
 - 1) The relay is reset from Lockout.
 - 2) A status input command is received.
 - 3) An appropriate IEC870 comms. Command is received.
- An event is recorded.
- The split flag can be mapped to an output relay for alarm indication.
- The system split LED will stay on for a minimum time, or can be latched using non self reset LEDs.

2.5.7 System Synchronising Mode

For the relay to issue a SystemSync Close the following conditions have to be met :

SYSTEM SYNC ANGLE – the phase difference between the line and bus voltages has to be less than the phase angle setting value and the phase angle has to be decreasing before the element will issue a valid close signal.

SYSTEM SYNC SLIP – the frequency difference between line and bus has to be less than the slip frequency setting value.

SYSTEM SYNC TIMER – the phase angle and voltage blocking features have to be within their parameters for the length of the slip timer setting. If either the phase angle or the voltage elements fall outside of their limits the slip timer is reset. If they subsequently come back in then the slip timer has to time out before an output is given. (This ensures that a close output will not be given if there is a transient disturbance on the system due to e.g. some remote switching operations).

LINE U/V DETECTOR – the line voltage has to be above the line undervoltage setting value and also above 5V for an output to be given.

BUS U/V DETECTOR – the bus voltage has to be above the line undervoltage setting value and also above 5V for an output to be given.

DIFFERENTIAL VOLTAGE DETECTOR – the difference between the line and bus voltages has to be less than the ΔV detector setting value for an output to be given.

Once a System Split has been detected, the settings A/R SPLIT ACTION and MC SPLIT ACTION define the conditions which must be met for closing to occur;

LOCKOUT : the relay will go into lockout mode and no closure is attempted.

CHECK SYNC: the relay will issue a Check Sync Close automatically if the relevant parameters are met.

SYSTEM SYNC: the relay will issue a System Sync Close automatically if the relevant parameters are met.

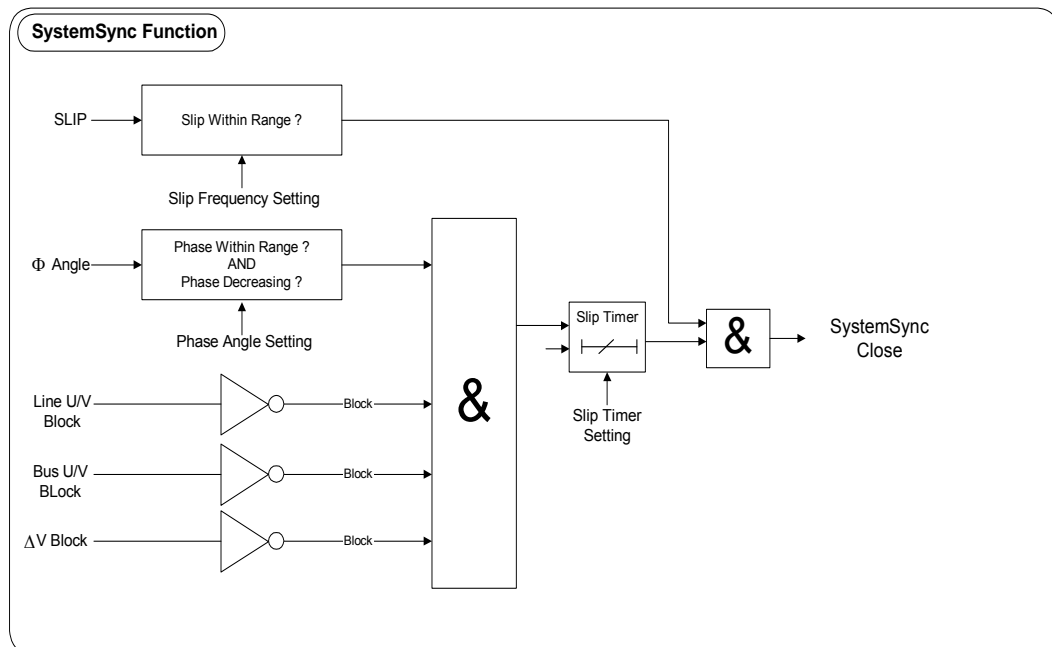

Figure 5 - System Sync Function

2.6 Metering

The metering feature provides real-time data available from the relay fascia in the 'Instruments Mode' or via the communications interface. The following displays are available :

- Phase difference between Line and Bus
- Frequency of both Line and Bus
- Frequency slip between Line and Bus
- RMS volts for both Line and Bus
- Voltage Differential between line and Bus
- Total Number of CB Closes
- Delta Number of CB Closes
- A/R Sequence Shot Number
- A/R State

Note : while the instrument displays are updated as often as the software routines can service them, some have their response time deliberately slowed down to enable them to be read.

3 Performance Specification

3.1 Accuracy

CS and SS Phase Angle measurement	
Operate	Setting $-3^{\circ} + 0^{\circ}$
Reset	operate value $-0^{\circ} + 3^{\circ}$
CS and SS Slip Frequency	
Operate	Setting $-15\text{mHz} + 0\text{mHz}$
Reset	operate value $-0\text{mHz} + 15\text{mHz}$
Split Detector measurement	
Operate	setting $\pm 1.5^{\circ}$
Reset	detector is latched
Line and Bus Voltage Detector Elements	
Live Operate	setting $\pm 1\%$
Live Reset	dead operate setting $\pm 1\%$
Dead Operate	setting $\pm 1\%$
Dead Reset	live operate setting $\pm 1\%$
Line and Bus U/V Detector Elements	
Operate	Setting $\pm 1\%$
Reset	$< 104\%$ of operate value
□V Detector Element	
Operate	Setting $\pm 2\%$ or 0.5V whichever is greater
Reset	Typically $> 90\%$ (and always within 2V) of operate value
All Timers	
Timing Accuracy	$\pm 1\%$ or 10ms

3.2 Accuracy General

Measuring Accuracy

Voltage	$\pm 1\%$ (for range $7\text{V}-132\text{Vrms}$)
Frequency	Typically $\pm 10\text{mHz}$
Phase	Typically $\pm 1^{\circ}$

3.3 Accuracy Influencing Factors

Temperature

Ambient Range	-10°C to $+55^{\circ}\text{C}$
Variation over range	$\leq 5\%$

Frequency

Range	47Hz to 51Hz 57Hz to 61Hz
Setting variation	$\leq 1\%$
Phase Angle Measurement	$\leq 1\%$
Operating time variation	$\leq 1\%$

7SG163 Ohmega 300 Series

7SG163 Protection Relay

Document Release History

This document is issue 2010/02. The list of revisions up to and including this issue is:
Pre release

2010/02	Document reformat due to rebrand

Contents

1	Introduction	3
2	DEF Direction and Characteristic Angle	3
2.1	DEF Schemes	4
2.1.1	DEF Direct Trip	4
2.1.2	DEF BOR	4
2.1.3	DEF POR	4
2.1.3.1	Current Reversal Guard	4
2.1.3.2	CB Echo	5
2.1.3.3	Weak End Infeed	5

1 Introduction

High resistance earth faults present difficulties to impedance measuring elements since the resistive coverage required can often extend beyond the apparent impedance presented by maximum load conditions. In those cases a directional earth fault element can be used to supplement the basic distance protection.

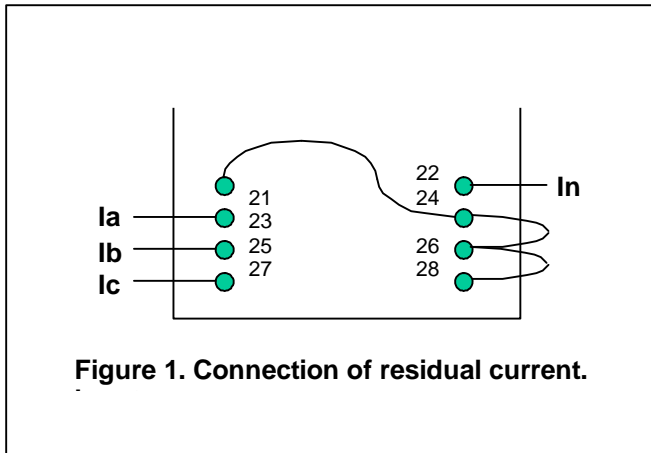

The relay applies two discrete directional elements, one in the forward direction, the other in the reverse direction.

The design of the directional earth fault elements is based on similar techniques as used for impedance measurement. The element is voltage polarised deriving this by summing the three phase to neutral voltages available in the relay. The zero sequence current providing the other input is derived from the fourth C.T. input which must be connected with the polarity as indicated in Figure 1.

2 DEF Direction and Characteristic Angle

The relay contains two directional elements - one forward and one reverse – which operate in parallel with each other. The forward DEF element will operate for fault current occurring in the forward direction – this element will be used for tripping. The reverse looking zone is usually a non-tripping element, used to generate a blocking signalling where a blocked overreach is applied.

The Characteristic Angle sets the maximum torque angle of the directional relay. Operation will occur for angles in the range $\pm 85^\circ$ of this setting. This should be set to the zero sequence impedance angle of the protected feeder.

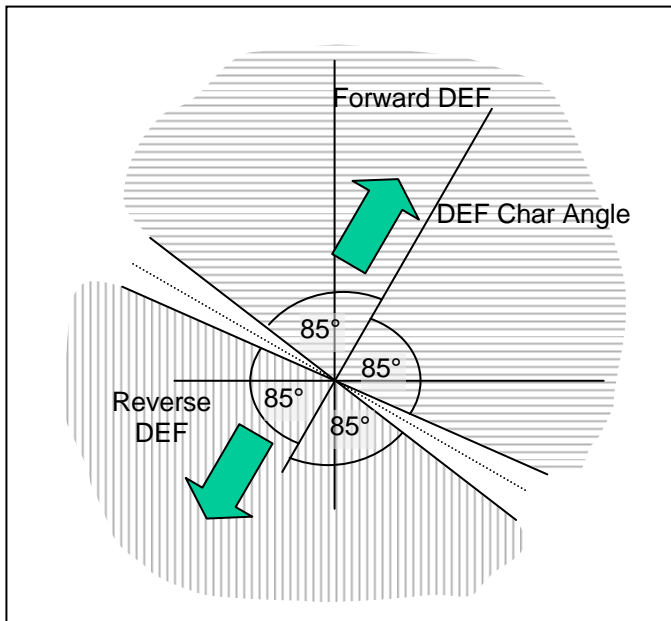

The DEF element can be used either in conjunction with a signalling channel, operating as a simple high speed directional comparison scheme with the remote end DEF, with an IDMTL backup function if a residual current is detected. Both blocking and permissive schemes are supported.

The element can also be used as a time graded directional IDMTL relay with no signalling. This mode is referred to as DEF DIRECT TRIP. More detail on these schemes is given in the next section.

Figure 2. DEF Operating Zones

2.1 DEF Schemes

There are three possible DEF schemes for the relay.

2.1.1 DEF Direct Trip

In the *DEF Direct Trip* mode, the relay will trip on detecting an earth fault in the set direction. The DEF element is time graded, and may be set to standard IEC or ANSI Curves or as a DTL element.

2.1.2 DEF BOR

The relay incorporates a DEF blocking scheme (*DEF BOR*). This is designed to be used in conjunction with a signalling channel. When the reverse-looking DEF element operates it sends a blocking signal, using the output contact assigned as *Signal Send 2*, to the remote end. In order to trip instantaneously on DEF the relay must detect a forward DEF and have NOT received a blocking signal to Status Input *Signal Receive 2* from the remote end. Obviously if one relay detects a fault in the forward direction, and it does not operate the reverse-looking DEF element at the remote end the fault must be within the line section, and tripping should be carried out as quickly as possible.

A short time delay, referred to as the DEF Permissive Trip Time is initiated, after the forward DEF element has picked up, to allow time for a blocking signal to be received from the remote end.

2.1.3 DEF POR

The permissive overreach scheme (*DEF POR*) is designed to be used in conjunction with a signalling channel. When the DEF element operates it sends a permissive signal, using the output contact assigned as *Signal Send 2*, to the remote end. In order to trip instantaneously on DEF the relay must detect a DEF and have received a signal to Status Input *Signal Receive 2* from the remote end. Obviously if the relays at both ends of the line detect a fault in the forward direction, the fault must be within the line section, and tripping should be carried out as quickly as possible.

In case the signalling channel fails, if the DEF element operates, and no signal is received from the remote end, the relay will carry out a time delayed DEF back-up trip.

Additional logic is included within the DEF Scheme to ensure correct operation of the relay.

2.1.3.1 Current Reversal Guard

A current reversal guard is included to prevent incorrect tripping on parallel feeders.

Consider a fault at Point F on the parallel line system shown below:

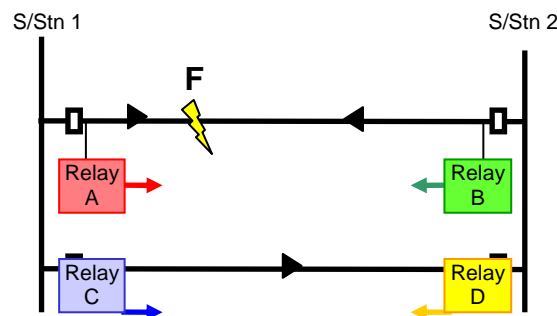

Both Relay A and Relay B will detect earth fault current in the forward direction. Both DEF elements will operate, permissive signals will be sent by both relays, and when these signals are received, Relays A and B will carry out a *DEF Aided Trip*, isolating the fault.

Observing the direction of current flow, Relay C will also detect earth fault current in the forward direction, and send a permissive signal to the remote end (Relay D). Relay D will detect earth fault current in the reverse direction, and will not operate when the permissive signal is received from Relay C.

Now consider a situation, where the circuit breaker controlled by Relay B operates slightly before the circuit breaker at A.

The direction of current seen by relays C and D will change, so Relay C will detect earth fault current in the reverse direction, and relay D will detect earth fault current in the forward direction.

Under these circumstances, there is a “race condition” between the drop off of the *Signal Send 2* output from relay C and the operation of the forward DEF element at relay D.

If the DEF element at D operates before the *Signal Send 2* from Relay C drops off, Relay D may mal-trip.

Thus, if the Circuit Breaker is closed, and the relay detects fault current in the reverse direction, the Current Reversal Guard logic is started. If the relay then detects a forward DEF it will enforce a time delay (the *DEF Current Reversal Reset*) on the DEF Aided Trip to allow the remote end *Signal Send 2* element to drop off.

2.1.3.2 CB Echo

The DEF POR scheme relies upon relays at both ends of the line detecting the fault. With the circuit breaker at one end of the line open, the DEF element at one end cannot operate. Thus no permissive signal can be sent, so the fault would not be cleared until after the *DEF Back-up Trip Delay* for an in-zone fault.

Thus, if the local Circuit Breaker is open AND a permissive signal is received from the remote end, the relay will send (or “echo”) a permissive signal back to the remote end. The duration of this permissive signal is set as the *POR CB Echo Pulse Width*

2.1.3.3 Weak End Infeed

If one end of the line has little or no source of fault current, the relay may not see enough fault current to cause a trip. Thus, if the relay has not detected a fault in either the forward or reverse direction, and a permissive signal is received from the remote end, AND there is a residual voltage present (DEF WI RES OV LEVEL), AND the local CB is closed, the relay will carry out a “Weak Infeed” Trip, and send a permissive signal to the remote end allowing it to carry out a carrier aided trip, also.

7SG1635 Ohmega 315

Protection Relays

Document Release History

This document is issue 2010/02. The list of revisions up to and including this issue is:
Pre release

2010/02	Document reformat due to rebrand

The copyright and other intellectual property rights in this document, and in any model or article produced from it (and including any registered or unregistered design rights) are the property of Siemens Protection Devices Limited. No part of this document shall be reproduced or modified or stored in another form, in any data retrieval system, without the permission of Siemens Protection Devices Limited, nor shall any model or article be reproduced from this document unless Siemens Protection Devices Limited consent.

While the information and guidance given in this document is believed to be correct, no liability shall be accepted for any loss or damage caused by any error or omission, whether such error or omission is the result of negligence or any other cause. Any and all such liability is disclaimed.

Contents

1	Overcurrent Guard	3
2	Settings	3

1 Overcurrent Guard

The relay is microprocessor based and the distance protection measuring elements run continuously on all fault loops and all zones. Previous generations of distance relays were unable to do this due to hardware limitations and power consumption issues. A common method to achieve adequate performance was to use Overcurrent Starting elements which when picked up would initiate the impedance measuring circuits which were otherwise inactive. One characteristic of this system was that distance trips could not occur if the fault current was below the Overcurrent starting setting. The Overcurrent Guard function in the relay produces an identical characteristic by applying an undercurrent blocking signal to the distance function.

This function can be used to provide a direct replacement for older relays where the overcurrent starting was used to provide additional current based protection grading or to prevent mal-operation caused by VT switchover schemes when a dedicated line VT is not available.

2 Settings

OC Guard (Enabled, **Disabled**)

Enables or disables the overall operation of the Overcurrent Guard function which can be used to set the minimum current level for which a Distance element operation can occur.

OC Guard Setting (0.01-25 xIn) **1.5xIn**

Sets the current level as a multiple of rated current which must be exceeded for a Distance protection operation to occur.

OC Guard Z1 (OCG Z1 Enabled, **OCG Z1 Disabled**)

OC Guard Z2 (OCG Z2 Enabled, **OCG Z2 Disabled**)

OC Guard Z3 (OCG Z3 Enabled, **OCG Z3 Disabled**)

OC Guard Z4 (OCG Z4 Enabled, **OCG Z4 Disabled**)

The zones upon which the current block is applied are individually selected using these settings. When Disabled the zone will operate for an impedance inside it regardless of the current level.

7SG163 Ohmega 300 Series

7SG163 Protection Relay

Document Release History

This document is issue 2010/02. The list of revisions up to and including this issue is:
Pre release

2010/02	Document reformat due to rebrand

The copyright and other intellectual property rights in this document, and in any model or article produced from it (and including any registered or unregistered design rights) are the property of Siemens Protection Devices Limited. No part of this document shall be reproduced or modified or stored in another form, in any data retrieval system, without the permission of Siemens Protection Devices Limited, nor shall any model or article be reproduced from this document unless Siemens Protection Devices Limited consent.

While the information and guidance given in this document is believed to be correct, no liability shall be accepted for any loss or damage caused by any error or omission, whether such error or omission is the result of negligence or any other cause. Any and all such liability is disclaimed.

Contents

1 Sensitive Earth Fault (SEF).....	3
------------------------------------	---

1 Sensitive Earth Fault (SEF)

In power systems where the path to earth has a very high resistivity, the fault current flowing can be very low, sometimes lower than that required to operate most Protective relays.

The sensitive earth fault protection is therefore set with the lowest practical setting and a long time delay. For SEF protection, grading is carried out by time rather than by current. Two concurrent timers are available in the relay, the SEF alarm timer, and the SEF trip timer.

Once the SEF element operates, the SEF alarm timer is started. After the alarm time delay, if the SEF is still present, the relay will energise the SEF Alarm output. The SEF trip timer will then start. Once the SEF trip timer has expired the relay will energise the SEF trip output. This mode of operation ensures that the alarm time cannot be set shorter than the trip time in error. The logic is shown in figure 1 below.

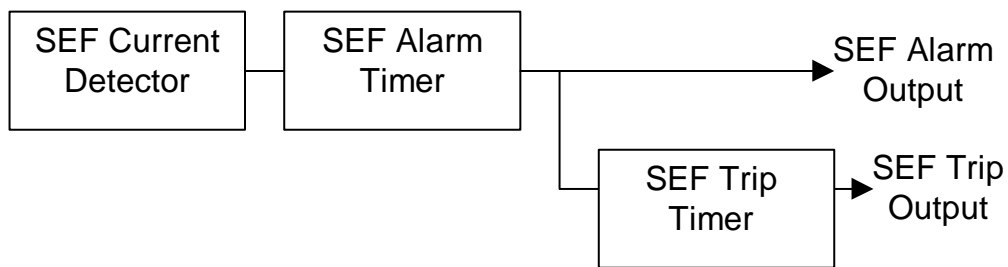

Figure 1. Logic Diagram for SEF Protection

7SG163 Ohmega 300 Series

7SG163 Protection Relay

Document Release History

This document is issue 2010/02. The list of revisions up to and including this issue is:
Pre release

2010/02	Document reformat due to rebrand

Contents

1	Voltage Protection	3
1.1	Analogue Inputs	3
1.2	Measuring Principles	3
2	Protection Functions	4
2.1	Voltage Blocking Element	4
2.2	Voltage Elements	4

1 Voltage Protection

The relay provides two independent elements for under-voltage (UV1 & UV2) and two independent elements for over-voltage (OV1 & OV2). The two levels allow for discrete alarm setting and trip settings, each with a separate pick-up and time delay setting. The undervoltage elements also incorporate a hysteresis setting, in order to allow the pick-up/drop-off ratio of the elements to be set. Undervoltage blocking detectors can be used to prevent nuisance alarms when the voltage inputs of the system are not energised.

The voltage elements can be used to protect generators against over-voltages, motors against loss of supply, or be applied as backup protection in the event of defective system regulating equipment.

1.1 Analogue Inputs

The input stage measures all three voltage quantities over the range of 5 Vrms to 90 Vrms it maintains accuracy within $\pm 1\%$ (or 0.25V) over the declared frequency performance range. The measuring range of the input stage allows for phase-neutral connections e.g. 63.5Vrms nominal voltages.

1.2 Measuring Principles

The main signal processing algorithm in the relay is a discrete Fourier transform (DFT) which is performed on each phase input. The DFT extracts the power system fundamental frequency component from the input voltages, effectively filtering out noise, D.C. and harmonics. The DFT is tuned for either 50 or 60Hz (depending upon the system frequency setting) and will calculate the real and imaginary components for each voltage input. These are then used to derive the magnitude quantity, which is then scaled to give a RMS value. Part of the DFT calculation includes extra filtering which smoothes the real and imaginary components, giving reduced ripple on the RMS calculation for off-system frequency conditions. In addition, a lookup table is used to compensate for magnitude variations from the output of the RMS calculation for 47-62Hz frequencies.

The real and imaginary components output from the DFT module are also used to derive the phase of the input signal.

2 Protection Functions

2.1 Voltage Blocking Element

The voltage blocking element acts as a block to the Voltage elements in the relay. If all phase voltages fall below the threshold level then the blocking operation will operate.

The setting range for the voltage blocking threshold is ENABLED/DISABLED, 3V - 60V in steps of 0.5V. This element is required for under-voltage operation conditions. Under normal circumstances, if all phase voltages fall below the under-voltage setting, the undervoltage element will operate. However, in some applications e.g. auto-reclose schemes, having an under-voltage relay trip when the line is de-energised during the auto-reclose sequence is not usually desirable. Blocking the under-voltage operation in this situation can be achieved by using the Voltage Blocking Threshold, which should generally be set above the level of expected induced voltages on the line.

Also it is undesirable to have an undervoltage alarm raised when the line is de-energised – the voltage blocking element can be used to prevent nuisance alarms.

2.2 Voltage Elements

The relay has 4 voltage elements as standard. These are configured as two under-voltage elements (UV1 and UV2, either of which can be used as alarms or trips) and two over-voltage elements (defined as OV Alarm, and OV Trip). If the input voltage(s) exceed the pickup level, whether U/V or O/V, then each element operates through a gate, which selects operation from any one phase or all phases. At this point the element can still be inhibited from starting if the input voltages are below the voltage blocking threshold level.

The undervoltage elements each have a variable Hysteresis setting which allows the user to vary the pick-up / drop-off ratio for a particular element.

[N.B. Remember that for an undervoltage element with hysteresis the pick-up of the element will occur at a lower voltage than the drop-off.]

The relay measures the voltage between each phase and neutral and will react to whichever phase exceeds the setting. If the setting is exceeded an LED is illuminated displaying over-voltage trip or alarm.

Data storage can only be initiated from a trip condition, either by operation of the Overvoltage trip output or operation of either UV1 or UV2 if tripping for that element is enabled.

The voltage elements are instantaneous transient free elements, which have independent DTL timers. The output can be set to 0s for instantaneous operation or time delayed up to 1000 ms.

To switch on the over-voltage functions they first have to be enabled in the AUXILIARY PROTECTION MENU. If the function is not enabled any applied settings for that function is ignored.

Published by and copyright © 2010:

Siemens AG
Energy Sector
Freyeslebenstrasse 1
91058 Erlangen, Germany

Siemens Protection Devices Limited

P.O. Box 8
North Farm Road
Hebburn
Tyne & Wear
NE31 1TZ
United Kingdom
Phone: +44 (0)191 401 7901
Fax: +44 (0)191 401 5575
www.siemens.com/energy

For more information, please contact our
Customer Support Center.

Phone: +49 180/524 70 00
Fax: +49 180/524 24 71 (Charges depending on provider)
E-mail: support.energy@siemens.com

Power Distribution Division Order No. C53000-G7076-C33-1
Printed in Fürth

Printed on elementary chlorine-free bleached paper.

All rights reserved.

Trademarks mentioned in this document are the property of Siemens AG, its affiliates, or their respective owners.

Subject to change without prior notice.

The information in this document contains general descriptions of the technical options available, which may not apply in all cases. The required technical options should therefore be specified in the contract.